

Home Portrait

NEW COLLECTION

/ 24



Vittoria Frigerio
MILANO

Home Portrait

NEW COLLECTION

/ 24



Victoria Frigerio
MILANO

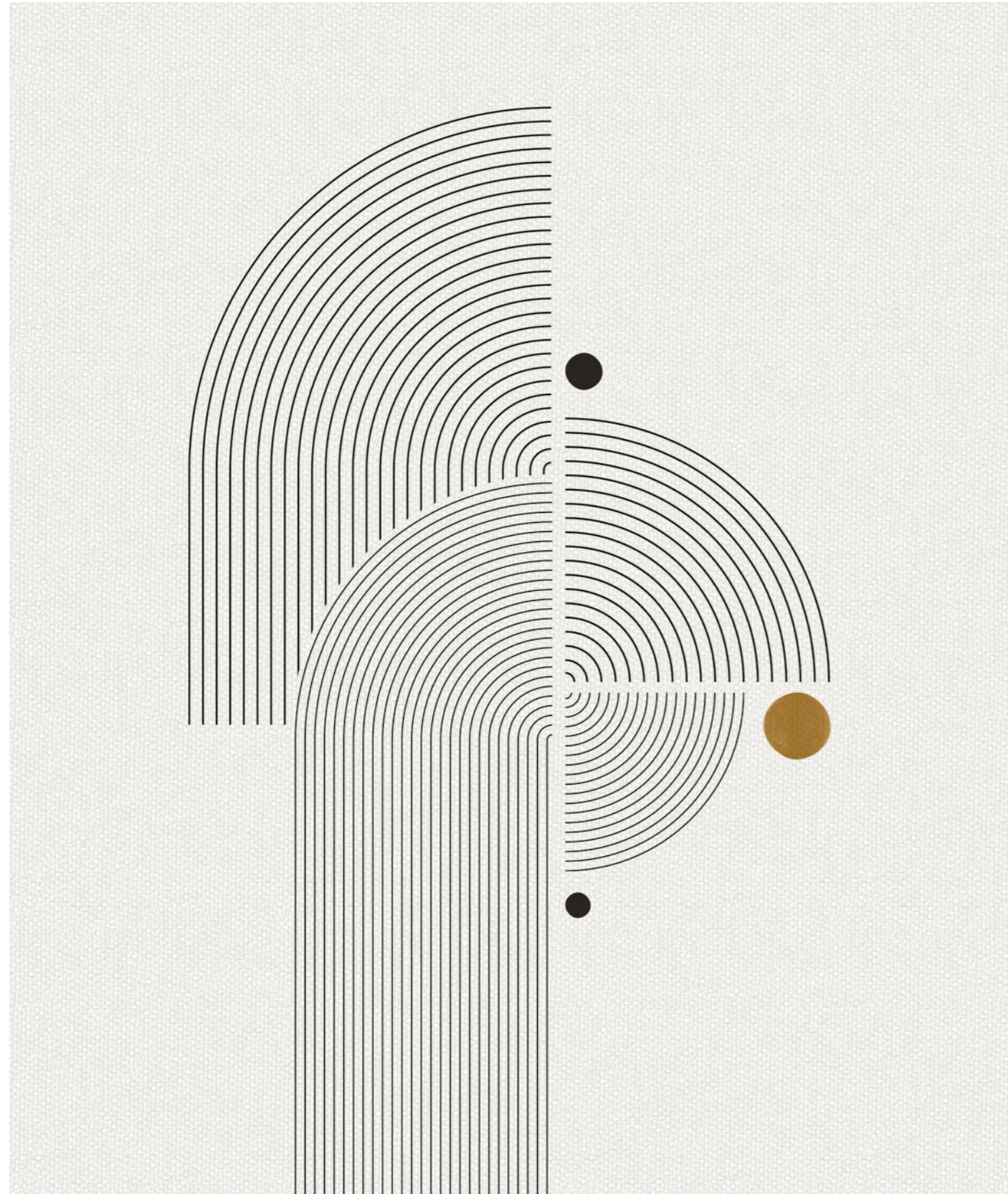

Alluring style and timeless elegance



Luca Erba



Giorgio Bonaguro



Studio Cattaneo



Andrea Bonini

L'eleganza formale, il rigore della perfezione e la ricercatezza dei dettagli sono i dictat della nuova collezione Vittoria Frigerio: un lifestyle glamour dal gusto contemporaneo arricchito grazie a consolidate collaborazioni come quella con lo Studio Cattaneo e le nuove firme stilistiche di Giorgio Bonaguro, Andrea Bonini e Luca Erba.

Tra contaminazioni raffinate e interpretazioni di classe, qualità eccellente e visioni poetiche, passato e presente si fondono nei nuovi arredi sartoriali di Vittoria Frigerio.

Il risultato è una collezione sorprendente che fa dell'eleganza estrema il suo punto di forza grazie ad una innovativa ricerca stilistica.

Formal elegance, the rigor of perfection and the refinement of details are the dictates of the new Vittoria Frigerio collection: a glamorous lifestyle with contemporary taste enriched thanks to consolidated collaborations such as the one with Studio Cattaneo and the new stylistic signatures of Giorgio Bonaguro, Andrea Bonini and Luca Erba.

Between refined contaminations and classy interpretations, excellent quality and poetic visions, past and present come together in Vittoria Frigerio's new tailoring furnishings.

The result is a surprising collection that makes extreme elegance its strong point thanks to innovative stylistic research.



Monaco
SOFA
6



Monaco
ARMCHAIR
14



Necchi
SOFA
34



Grace
CHAIR WITH ARMRESTS
42



Leni
SMALL TABLE
18



Monroy
TABLE
24



Brera
BENCH & DAYBED
48



Lario
BED
54



Monroy
CONSOLE
30



Monroy
SERVER
32



Mora
CHAIR WITH ARMRESTS
60



Mora
LOVESEAT
64



Roma
BOOKCASE
68

Monaco

SOFA DESIGN BY LUCA ERBA

Il divano Monaco è caratterizzato da un'intrigante rotondità della struttura, che abbraccia il cuscino monovolume di seduta, appoggiato su una base in pelle. Il dettaglio del bracciolo si sovrappone elegantemente alla seduta, diventandone il segno distintivo per un raffinato elemento decorativo.

The sofa Monaco features a charming roundness for the structure, which embraces the monovolume padded seat cushion, resting on a leather base. The detail of the armrest elegantly overlaps the seat, becoming the design hallmark for a fine decorative feature.



Monaco SOFA / Leni SMALL TABLE / Casati CARPET



Monaco SOFA / Monaco ARMCHAIR / Leni SMALL TABLE / Lanza SIDEBOARD / Casati CARPET



Linee curve e seduta accogliente caratterizzano il divano Monaco, per un'atmosfera raffinata e innovativa, grazie alla forma tonda della struttura.

Curved lines and cosy seating characterise the Monaco sofa, for a refined and innovative atmosphere, thanks to the round shape of the structure.



Monaco SOFA / Monaco ARMCHAIR / Leni SMALL TABLE / Cusani CARPET

Monaco

ARMCHAIR DESIGN BY LUCA ERBA

Il segno distintivo del bracciolo, che si sovrappone morbidamente al cuscino imbottito della seduta monovolume, diventa la caratteristica principale della poltrona Monaco, parte dell'omonima collezione. Un'isola di estremo benessere dal design raffinato per un living dal gusto glamour e contemporaneo.

The hallmark of the armrest softly overlapping on the padded monovolume seating cushion becomes the main feature of the armchair Monaco, part of the namesake collection. An island of extreme coziness and refined design for a living with a glamour contemporary taste.



Monaco ARMCHAIR / Cusani CARPET



Silhouette avvolgente dalla forma sinuosa, la poltrona Monaco esalta il design e la cura dei dettagli della collezione Vittoria Frigerio per un arredo di personalità di grande eleganza.

An enveloping silhouette with a sinuous shape, the Monaco armchair enhances the design and attention to detail of the Vittoria Frigerio collection for a very elegant piece of furniture with personality.



Leni

SMALL TABLE DESIGN BY LUCA ERBA

Il tavolino Leni sorprende per il design inaspettato del piano rotondo in marmo che non completa il suo perimetro circolare, creando un abbraccio tra le due estremità arrotondate del cerchio che rimane aperto. Il corpo centrale, in laccato lucido, fornisce ulteriori dettagli per un elemento che unisce funzionalità e design.

The small table Leni surprises you with an unexpected design of the marble round top which does not complete its circular perimeter, by creating an embrace between the two rounded ends of the circle which remains uncomplete. The central body, in lacquered glossy colour, provides further furnishing details to this extremely decorative small table for your living room.



Leni SMALL TABLE / Monaco SOFA / Cusani CARPET



Un raffinato design per il tavolino Leni con top tondo in marmo, che crea un contrasto armonioso con la struttura laccata lucida per un tocco sofisticato nella zona living.

A refined design for the Leni coffee table with round marble top, which creates a harmonious contrast to the glossy lacquered frame for a sophisticated touch in the living area.





Leni SMALL TABLE / Monaco SOFA / Cusani CARPET

Monroy

TABLE DESIGN BY GIORGIO BONAGURO

Il tavolo da pranzo Monroy mette in risalto il design delle gambe a forma di due vele contrapposte dando vita a una soluzione da pranzo dalle linee nette e pure, enfatizzando l'uso dei materiali. Il piano è in marmo e per le gambe si nota un inaspettato abbinamento: la gamba è in marmo e la parte esterna è rivestita da una lastra di metallo, per un forte contrasto materico.

The dining table Monroy highlights the design of the legs shaped like two opposite sails giving life to a dining solution featuring sharp and pure lines by emphasizing the use of the materials. The top is made of marble and the legs feature an unexpected match: the leg is in marble and the external part is covered by a metal plate, for a strong contrast of matter.



Monroy TABLE / Grace CHAIR WITH ARMRESTS / Casati CARPET



Il tavolo Monroy in marmo con inserti in metallo rappresenta il connubio perfetto fra lusso e modernità. Un segno distintivo e sofisticato per la zona dining.

The Monroy marble table with metal inserts represents the perfect combination of luxury and modernity. A distinctive and sophisticated object for the dining area.



Monroy TABLE / Grace CHAIR WITH ARMREST / Doge BOOKCASE / Casati CARPET

Monroy

CONSOLE DESIGN BY GIORGIO BONAGURO

La console Monroy è caratterizzata da un design aereo grazie all'unica gamba che sostiene la console, a sua volta fissata alla parete. Monroy evidenzia un design estremo e puro, dove i materiali diventano i veri protagonisti della collezione con la gamba in marmo rivestita da un lato da una lastra di metallo.

The console Monroy features an aerial design thanks to the single leg supporting the console, fixed to the wall. Monroy features an extreme pure design where the materials become the true protagonists of the collection with the leg in marble covered on one side with a metal plate.



Monroy CONSOLE / Miani MIRROR

Monroy

SERVER DESIGN BY GIORGIO BONAGURO

Con un design minimalista e una silhouette puramente delineata, il server Monroy presenta un piano in marmo e una base a forma di triangolo aperto rovesciato, per un'aggiunta funzionale e raffinata alla zona living.

With a minimalistic design and a pure sharp silhouette, the server Monroy features a marble top and a base shaped like a reverse open triangle for a functional and refined addition to the living room.



Monroy SERVER / Spinola SOFA

Necchi

SOFA DESIGN BY ANDREA BONINI

Il divano Necchi è caratterizzato da linee rigorose per un design contemporaneo che accoglie seduta e schienale imbottiti, delineati dal dettaglio lussuoso del rivestimento in pelle che si estende dalla base del divano per salire lungo i frontali dei braccioli, per una sofisticata attestazione di purezza estetica.

Necchi sofa features rigorous lines for a contemporary design welcoming padded seat and back cushions, outlined by the luxury detail of the leather cover extending from the sofa base to the armrests' fronts, for a sophisticated statement of aesthetical purity.



Necchi SOFA / Adami SMALL TABLE



Necchi SOFA / Adami SMALL TABLE / Monroy CONSOLE / Palladio MIRROR



Espressione di una sofisticata eleganza, il divano Necchi esalta la capacità sartoriale di Vittoria Frigerio grazie al frontale rivestito in pelle per un'estetica senza tempo che coniuga lusso e funzionalità.

An expression of sophisticated elegance, the Necchi sofa enhances Vittoria Frigerio's tailoring skills with its leather-covered front for a timeless aesthetic that combines luxury and functionality.





Necchi SOFA / Adami SMALL TABLE

La sovrapposizione di materiali e forme enfatizza la bellezza del divano Necchi caratterizzato da un dettaglio in pelle che ricopre sia la base che la parte anteriore dei braccioli per un vero e proprio segno distintivo dal design dinamico e aggraziato allo stesso tempo.

The overlapping of materials and shapes emphasizes the beauty of the Necchi sofa characterized by a leather detail that covers both the base and the front of the armrests, making for a true hallmark of design that is both dynamic and graceful.



Grace

CHAIR WITH ARMRESTS DESIGN BY ANDREA BONINI

Sedia con braccioli che con linee pulite e rigorose definisce un design costruttivo di grande tecnica grazie ad una struttura in legno dalla silhouette aerea che trasforma le gambe in braccioli per una seduta esteticamente pura e accogliente. L'uso di materiali diversi e i dettagli sartoriali dei cuscini di seduta e schienale evidenziano lo spirito manifatturiero della collezione.

A chair with armrests whose clean, rigorous lines defines a highly technical construction silhouette with an aerial wooden frame that transforms the legs into armrests for an aesthetically pure and welcoming seat. The use of different materials and the tailoring details of the seat and back cushions highlight the handcrafted spirit of the collection.



Grace CHAIR WITH ARMRESTS / Monroy TABLE / Casati CARPET



Maestria artigianale e design senza tempo si combinano armoniosamente grazie all'uso sapiente di materiali esclusivi come il legno massello per la struttura e il mix fra tessuto e pelle per la seduta e schienale.

Craftsmanship and timeless design are harmoniously combined thanks to the skilful use of exclusive materials such as solid wood for the structure and the mix of fabric and leather for the seat and backrest.



Monroy TABLE / Grace CHAIR WITH ARMREST / Casati CARPET

Brera

BENCH & DAYBED DESIGN BY ANDREA BONINI

Un nuovo oggetto per il living, che può essere utilizzato come panca sia nella zona giorno che nella zona notte. La versione daybed crea nuovi spazi di seduta e comfort. Brera è anche disponibile nella versione decorativa e funzionale con piano di appoggio integrato per offrire una maggiore superficie d'appoggio.

A new furnishing object that can be used as bench both in the living and in the night area. The daybed version creates new spaces for seating and comfort. Brera is also available in a decorative and functional version with an integrated top to provide more storage space.



Brera Plain BENCH / Lario Plain BED / Salis NIGHT TABLE



Eleganza senza tempo e materiali pregiati si incontrano nella panca Brera. Il rivestimento in tessuto avvolge la seduta, mentre gli inserti in pelle conferiscono un tocco di lusso e raffinatezza. Le gambe in legno massello sono impreziosite da dettagli in oro per un elemento d'arredo che unisce stile, comfort e unicità.

Timeless elegance and fine materials meet in the Brera bench. The seat is covered in precious fabric, while leather inserts add a touch of luxury and refinement. The solid wood legs are embellished with gold details for a piece of furniture that combines style, comfort and uniqueness.





Brera Plain BENCH / Necchi SOFA

Lario

BED DESIGN BY ANDREA BONINI

Il letto Lario porta il design, la purezza delle linee e il rigore progettuale nel comfort di un letto lussuoso caratterizzato da un'alta testata con un'elegante struttura in legno che incornicia un pannello in tessuto o pelle impreziosito da cuscini decorativi per un delicato equilibrio tra la solida base e la leggera testata.

The Lario bed brings design, purity of lines, and architectural rigor to the comfort of a luxurious bed featuring a high headboard with an elegant wooden structure that frames a fabric or leather panel embellished with decorative pillows for a delicate balance between the solid base and light headboard.



Lario Quilt BED



Lario Plain BED / Brera Plain BENCH / Salis NIGHT TABLE / Miani MIRROR / Pisani CARPET



Stile e raffinatezza caratterizzano il letto Lario per trasformare la zona notte in un'oasi di lusso. La maestosa testata è impreziosita da una trapunta in pelle che conferisce un senso di esclusività e comfort. Lusso, artigianalità e un'estetica impeccabile sono i segni distintivi di questo protagonista della zona notte.

Style and sophistication characterise the Lario bed to transform the night area into an oasis of luxury. The majestic headboard is embellished with a leather quilted insert that lends a sense of exclusivity and comfort. Luxury, craftsmanship and impeccable aesthetics are the hallmarks of this main character of the night area.



Mora

CHAIR WITH ARMRESTS DESIGN BY STUDIO CATTANEO

All'omonima collezione si aggiunge una sedia con braccioli caratterizzata dalla struttura in legno massello che dai braccioli si estende nella base semicircolare per un'elegante sedia per la zona dining. La sedia con braccioli Mora arreda con uno stile senza tempo la sala da pranzo, grazie alla struttura in legno e alla seduta rivestita in materiali ricercati.

A chair with armrests is added to the collection of the same name, featuring a solid wood frame extending from the armrests into the semicircular base for an elegant dining chair. The Mora chair with armrests furnishes the dining area with timeless style, thanks to its wooden frame and seat upholstered in refined materials.



Mora CHAIR WITH ARMRESTS / Corsini TABLE / Casati CARPET



La sedia Mora con braccioli è un progetto che coniuga forma e funzione e grazie alla struttura in legno massello viene esaltata l'artigianalità della produzione Vittoria Frigerio. Perfetta per ambienti living o dining, aggiunge un elemento di classe a qualsiasi spazio.

The Mora chair with armrests is a design that combines form and function, and thanks to the solid wood frame the craftsmanship of Vittoria Frigerio production is enhanced. Perfect for living or dining environments, it adds an element of class to any space.

Mora

LOVESEAT DESIGN BY STUDIO CATTANEO

Un piacevole elemento d'arredo in cui la rotondità della base crea un'isola di comfort e relax, dando vita a un loveseat caratterizzato dai dettagli della collezione Mora: un'elegante struttura in legno con schienale imbottito e cuscini di seduta con cucitura verticale.

A pleasing furnishing element where the roundness of the base creates an island of comfort and relaxation by creating a loveseat featuring the details of the Mora collection: sleek wooden frame with padded back and seat cushions with vertical sewing.



Mora LOVESEAT



Mora LOVESEAT / **Vivaldi** SOFA / **Adami** SMALL TABLE / **Cusani** CARPET

Roma

BOOKCASE DESIGN BY R&D VITTORIA FRIGERIO

Una libreria a giorno che può essere utilizzata come elemento singolo o sovrapponendole tra loro oppure affiancandole liberamente. Un intrigante elemento d'arredo per la zona living che dona un tocco di modernità per la libertà compositiva e per un tocco di tradizione grazie alla struttura in legno.

An open bookcase that can be used as a single element or by overlapping them or by freely placing them side by side. An intriguing piece of furniture for the living area that gives a touch of modernity thanks to the modularity freedom and a touch of tradition thanks to the wooden structure.



Roma BOOKCASE / Spinola SOFA / Adami SMALL TABLE / Cusani CARPET



La libreria Roma si caratterizza da elementi sovrapponibili con dettagli esclusivi, come gli inserti in cuoio e i ripiani in vetro bronzato, per un risultato estetico di grande ricercatezza formale senza rinunciare alla funzionalità.

Roma bookcase features stackable elements with exclusive details such as hide-leather inserts and bronzed glass shelves, for an aesthetic result of great formal refinement without sacrificing functionality.



Roma BOOKCASE / Spinola SOFA / Adami SMALL TABLE / Cusani CARPET

NECCHI / PAG 34

SOFA DESIGN BY ANDREA BONINI



Collezione di divani ed elementi componibili in tessuto o pelle con rivestimento non sfoderabile. Basamento rivestito in pelle così come la parte anteriore dei braccioli, sempre con rivestimento fisso.

Collection of sofas and modular elements in fabric or leather with fixed cover. Base covered in leather as well as the front part of the armrests, always with fixed cover.

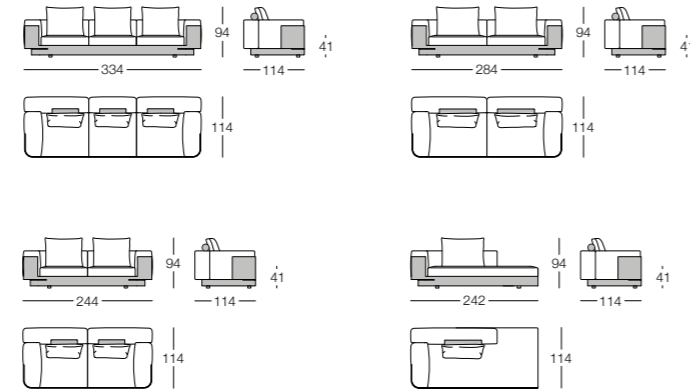

MONACO / PAG 6

SOFA DESIGN BY LUCA ERBA



Collezione di divani ed elementi componibili in tessuto o pelle con rivestimento non sfoderabile. Basamento rivestito in pelle. Completa la collezione una poltrona.

Collection of sofas and modular elements in fabric or leather with fixed cover. Base in leather. An armchair completes the collection.

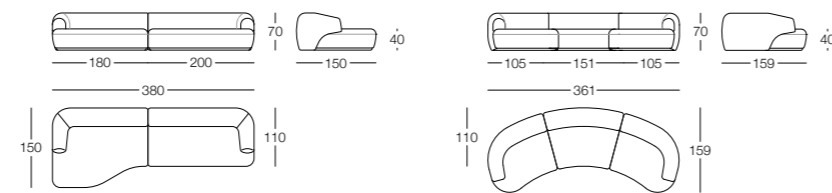

MONACO / PAG 14

ARMCHAIR DESIGN BY LUCA ERBA



Poltrona in tessuto o pelle con rivestimento non sfoderabile. Basamento rivestito in pelle.

Armchair in fabric or leather with fixed cover. Base in leather.

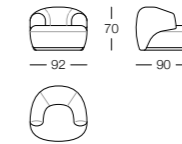

MORA / PAG 64

LOVESEAT DESIGN BY STUDIO CATTANEO



Loveseat con struttura a vista in legno massello e parti imbottite rivestite in tessuto o pelle con rivestimento non sfoderabile. Cuscino seduta e schienale impreziositi da ricami dedicati.

Loveseat with visible solid wood structure and padded parts covered in fabric or leather with a non-removable cover. Seat and back cushion enriched with dedicated embroidery.

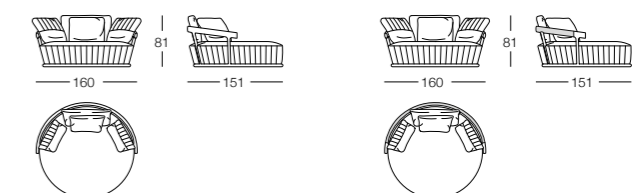

MORA / PAG 60

CHAIR WITH ARMRESTS DESIGN BY STUDIO CATTANEO



Sedia con braccioli con struttura a vista in legno massello e cuscino di seduta imbottito rivestito in tessuto o pelle, rivestimento non sfoderabile.

Chair with armrests with visible solid wood structure and padded seat cushion covered in fabric or leather, fixed cover.

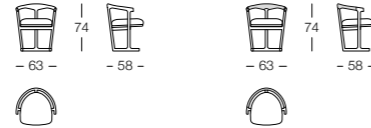

GRACE / PAG 42

CHAIR WITH ARMRESTS DESIGN BY ANDREA BONINI



Sedia con braccioli con gambe e braccioli in legno. Scocca di seduta e braccioli in legno imbottita internamente, con parte esterna rifinita con ricamo in rilievo, in tessuto o pelle. Cuscino schienale imbottito in tessuto o pelle. Disponibile anche nella versione rivestita internamente in tessuto e esternamente in pelle.

Chair with armrests with legs and armrests in solid wood. Seat and armrests body in wood padded internally, with the external part realized with embroidery in relief, in fabric or leather. Padded back cushion in fabric or leather. Available also in the version with internal part covered in fabric and external part in leather.

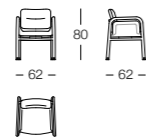

MONROY / PAG 24

TABLE DESIGN BY GIORGIO BONAGURO



Collezione di tavoli da pranzo di varie dimensioni con top in marmo. Gambe in marmo nella stessa finitura del piano, impreziosite da pannelli decorativi in metallo nella parte esterna.

Collection of dining table in different sizes with marble top. Legs in marble in the same finish of the top enriched by a decorative metal panel on the external part of them.

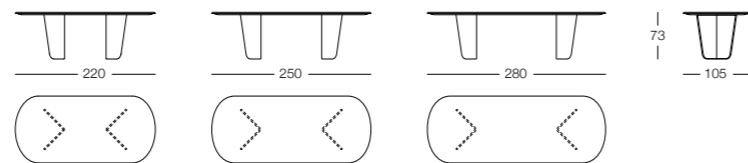

LENI / PAG 18

SMALL TABLE DESIGN BY LUCA ERBA



Collezione di tavolini in varie dimensioni con struttura e parte centrale del top in finitura laccato lucido. Top in marmo definito da un anello aperto con angoli stondati.

Collection of small tables in different sizes with structure and central top in glossy lacquered finish. Marble top defined by an open ring with rounded ends.

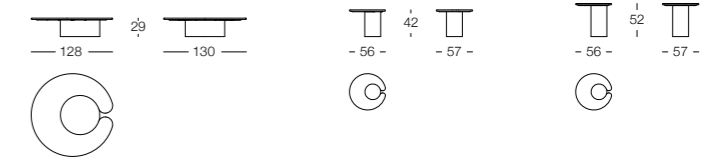

MONROY PAG 30

CONSOLE DESIGN BY GIORGIO BONAGURO



Console con gamba singola e fissaggio a muro. Top in marmo. Gamba in marmo nella stessa finitura del piano, impreziosita da un pannello decorativo in metallo nella parte esterna.

Console with single leg and wall mounting. Marble top. Leg in marble in the same finish of the top enriched by a decorative metal panel on the external part of it.

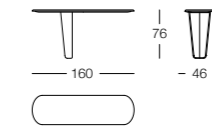

MONROY PAG 32

SERVER DESIGN BY GIORGIO BONAGURO



Server con gamba centrale con top in marmo. Gamba in marmo nella stessa finitura del top con pannello decorativo in metallo nella parte esterna.

Server with central leg with marble top. Leg in the same marble of the top with a decorative metal panel on the external part of it.

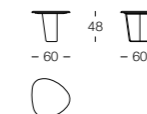

BED DESIGN BY ANDREA BONINI

Collezione di letti completi di rete a doghe in legno (materasso escluso). Giroletto rivestito in tessuto o pelle non sfoderabile con basamento in pelle. Testata con cornice esterna in legno massello e dettagli in metallo e con inserto imbottito rivestito in tessuto o pelle. Disponibile nella versione Plain e Quilt.

Collection of beds with wooden slatted base (mattress excluded). Bedframe covered in non-removable fabric or leather with a leather base. Headboard with solid wood outer frame with metal details and upholstered insert covered in fabric or leather. Available in the Plain and Quilt version.

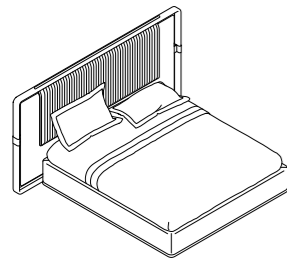

LARIO QUILT

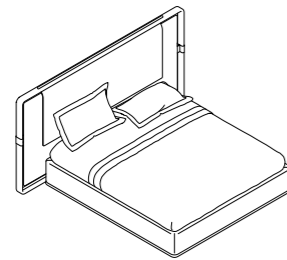

LARIO PLAIN

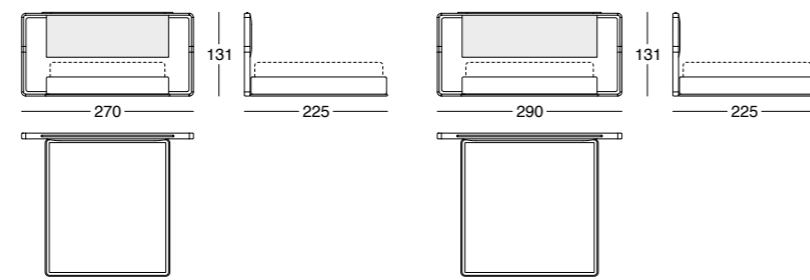

BENCH & DAYBED DESIGN BY ANDREA BONINI

Collezione di panche in diverse dimensioni con struttura in legno massello e dettagli in metallo. Basamento rivestito in pelle con fascia decorativa in pelle incrociata alle estremità del cuscino seduta. Cuscino seduta rivestito in pelle o tessuto non sfoderabile, disponibile nella versione liscia o con trapunta dedicata. Disponibile la versione panca con top integrato e nella versione Plain e Quilt.

Collection of benches in different sizes with solid wooden frame and metal details. Leather base with decorative crisscrossed leather band at the end sides of the seat cushion. Seat cushion with non-removable cover in leather or fabric, available in either plain or in a dedicated quilted version. Bench version with integrated top and in the Plain and Quilt version.

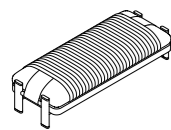

BRERA QUILT

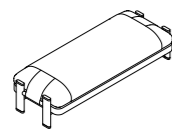

BRERA PLAIN

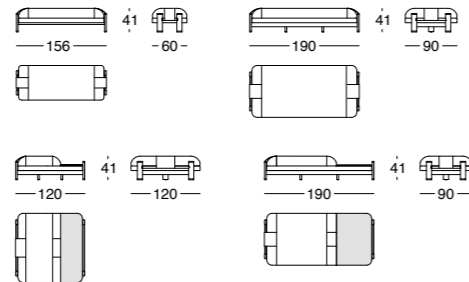

BOOKCASE DESIGN BY R&D VITTORIA FRIGERIO

Libreria con struttura cilindrica in legno con inserti in cuoio, disponibile in due altezze e due versioni, con o senza ripiano centrale in vetro. Libreria impilabile e con luce led lungo l'altezza. Versione non girevole.

Bookcase with cylindrical wooden structure with hide-leather inserts, available in two heights and two versions, with or without central glass shelf. Stackable bookcase with led light along the height. Non-swiveling version.

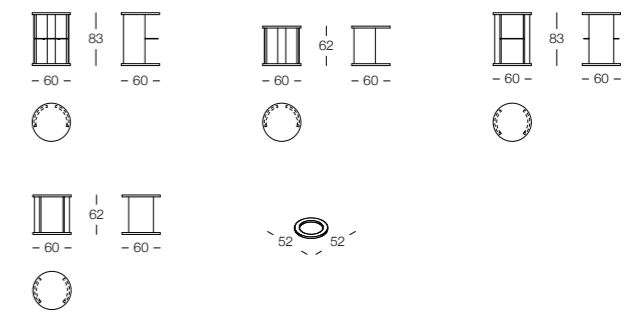

COMPOSIZIONI / COMPOSITIONS

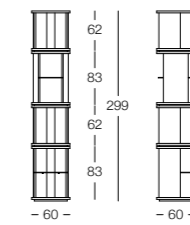

Comp. A

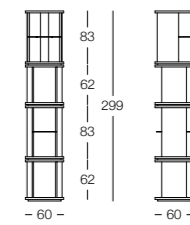

Comp. B

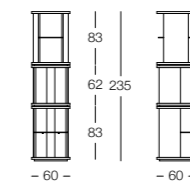

Comp. C

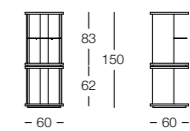

Comp. D

Art Direction:

Euro Sironi

Graphic Project:

Michela Boglietti

Project Coordination:

R&D Frigerio

Photo:

Studio Eleven

Images:

Francesca Fani Studio

Styling:

Euro Sironi

Colour Separation:

CD Cromo

Printing:

Grafiche Antiga



FRIGERIO POLTRONE E DIVANI SRL
Via Sant'Agata, 63
22066 Mariano Comense CO - Italy
T. +39 031 5481225
info@vittoriafrigerio.it
www.vittoriafrigerio.it