

Home Portrait

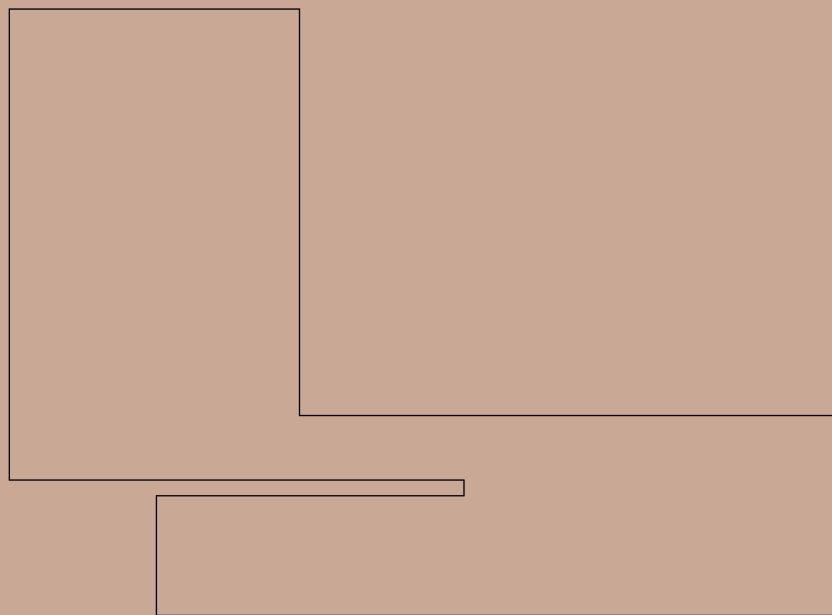

Vittoria Frigerio
— MILANO —

Home Portrait



Vittoria Frigerio
MILANO

L'eleganza formale, il rigore della perfezione e la ricercatezza dei dettagli sono i dictat della collezione Vittoria Frigerio: un lifestyle glamour dal gusto contemporaneo. Tra contaminazioni raffinate e interpretazioni di classe, qualità eccellente e visioni poetiche, passato e presente si fondono grazie a linee fluide, materiali pregiati e un'estetica che celebra la bellezza organica: la nuova collezione di arredi luxury di Vittoria Frigerio ridefinisce il concetto di living con un'armonia perfetta tra natura e glamour. Forme morbide e sinuose evocano paesaggi dove inaspettati archi e centine rimangono scolpiti dal tempo e nello spazio, mentre dettagli sofisticati e finiture esclusive esaltano il carattere distintivo di ogni pezzo. La collezione si arricchisce grazie alla collaborazione con Giorgio Bonaguro, Andrea Bonini, Luca Erba e Studio Cattaneo dove ogni oggetto nasce dall'incontro tra ricerca estetica e maestria artigianale, abbinando materiali pregiati in contrasti di colore e calore per ambienti con un fascino senza tempo. Un'esperienza sensoriale che trasforma lo spazio in un'opera d'arte da vivere.

Formal elegance, the rigor of perfection and the refinement of details are the dictates of the new Vittoria Frigerio collection: a glamorous lifestyle with contemporary taste. Between refined contaminations and classy interpretations, excellent quality and poetic visions, past and present come together thanks to flowing lines, fine materials and an aesthetic that celebrates organic beauty: the new luxury furniture collection by Vittoria Frigerio redefines the concept of living with a perfect harmony between nature and glamour. Soft, sinuous forms evoke landscapes where unexpected arches remain sculpted by time and space, while sophisticated details and exclusive finishes enhance the distinctive character of each piece. The collection is enriched thanks to the collaboration with Giorgio Bonaguro, Andrea Bonini, Luca Erba and Studio Cattaneo where each piece is born from the encounter between aesthetic research and craftsmanship, combining fine materials in contrasts of color and warmth for environments with timeless appeal. A sensory experience that transforms space into a work of art to be experienced. Discover the perfect balance between design and glamour.

Alluring style and timeless elegance



Giorgio Bonaguro



Luca Erba



Andrea Bonini



Studio Cattaneo



Noah
SOFA
7



Necchi
SOFA
23



Audrey
CHAIR & SMALL ARMCHAIR
77



Grace
SMALL ARMCHAIR
83



Mora
CHAIR
89



Monaco
SOFA
35



Mora
LOVESEAT
57



Necchi
SMALL TABLE & SERVER
93



Leni
SMALL TABLE
99



Monroy
SERVER & CONSOLE
105/107



Audrey
ARMCHAIR
45



Necchi
ARMCHAIR
49



Monaco
ARMCHAIR
53



Brera
BENCH & DAYBED
109



Lario
BED
117



Carrera
SCREEN PANEL
123



Gregory
TABLE
65



Monroy
TABLE
71



Daisy
VASES
149



Chloé
BOOKCASE
129



Vivienne
BOOKCASE
135



Roma
BOOKCASE
143

Noah

SOFA DESIGN BY R&D VITTORIA FRIGERIO

Come un'architettura sospesa tra arte e natura, il divano Noah sinuoso e curvo per sua natura, incarna la perfetta fusione tra design e poesia. Le sue forme morbide e fluide si intrecciano in un equilibrio armonioso, mentre le fasce verticali che ne scandiscono la struttura e il ritmo evocando le centine di maestose volte architettoniche, reinterpretandole in chiave contemporanea.

Like an architecture suspended between art and nature, the Noah sofa sinuous and curved by nature, embodies the perfect fusion of design and poetry. Its soft, flowing forms intertwine in harmonious balance, while the vertical bands that punctuate its structure and rhythm evoke the arches of majestic architectural vaults, reinterpreting them in a contemporary key.



Noah SOFA / Monroy SERVER & CONSOLE



Noah SOFA / Monroy SERVER & CONSOLE / Palladio MIRROR



L'attenzione ai dettagli esalta la bellezza del divano Noah, in cui ogni singolo elemento è un modulo imbottito con cura, che nel suo insieme dà vita a un design sinuoso, adatto sia agli spazi contract sia a quelli residenziali.

Attention to detail enhances the beauty of the Noah sofa, where each individual element is a carefully crafted padded unit, coming together to create a sinuous design suitable for both contract and residential spaces.





Noah SOFA / Reina ARMCHAIR / Adami SMALL TABLE / Monroy SERVER

Animo votato al comfort avvolgente, un ritmo visivo che gioca con luci e ombre, il divano Noah esalta sia l'uso residenziale che contract per un risultato inaspettato.

A soul devoted to enveloping comfort, a visual rhythm that plays with light and shadow, the Noah sofa enhances both residential and contract use for an unexpected result.



Noah SOFA / Leni SMALL TABLE / Lanza SIDEBOARD



Noah SOFA / Leni SMALL TABLE / Lanza SIDEBOARD / Cusani CARPET



Noah SOFA / Audrey ARMCHAIR / Biffi SMALL TABLE

*Natural texture
for glamour lifestyle*



CALACATTA ORO
Marble



NABUK 1008
Leather



GROSGRAIN A14
Piping



ERICE 06
Fabric

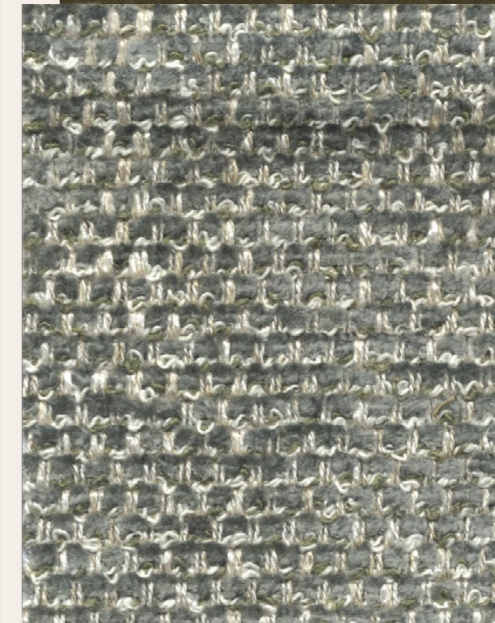

ASHWOOD TOBACCO COLOUR
Wood



SANREMO 03
Fabric

Necchi

SOFA DESIGN BY ANDREA BONINI

Il divano Necchi è caratterizzato da linee rigorose per un design contemporaneo che accoglie seduta e schienale imbottiti, delineati dal dettaglio lussuoso del rivestimento in pelle che si estende dalla base del divano per salire lungo i frontali dei braccioli, per una sofisticata attestazione di purezza estetica.

Necchi sofa features rigorous lines for a contemporary design welcoming padded seat and back cushions, outlined by the luxury detail of the leather cover extending from the sofa base to the armrests' fronts, for a sophisticated statement of aesthetical purity.



Necchi SOFA / Necchi SMALL TABLE & SERVER / Monroy CONSOLE / Miani MIRROR



Necchi SOFA / Necchi SMALL TABLE & SERVER / Monroy CONSOLE / Miani MIRROR



Necchi SOFA & ARMCHAIR / Adami SMALL TABLE / Araldo CONSOLE
Gregory TABLE / Audrey SMALL ARMCHAIR / Miani MIRROR / Cusani CARPET



Espressione di una sofisticata eleganza, il divano Necchi esalta la capacità sartoriale di Vittoria Frigerio grazie al frontale rivestito in pelle per un'estetica senza tempo che coniuga lusso e funzionalità.

An expression of sophisticated elegance, the Necchi sofa enhances Vittoria Frigerio's tailoring skills with its leather-covered front for a timeless aesthetic that combines luxury and functionality.





Necchi SOFA / Adami SMALL TABLE / Monroy CONSOLE / Palladio MIRROR



Necchi SOFA / Adami SMALL TABLE / Monroy CONSOLE

La sovrapposizione di materiali e forme enfatizza la bellezza del divano Necchi caratterizzato da un dettaglio in pelle che ricopre sia la base che la parte anteriore dei braccioli per un vero e proprio segno distintivo dal design dinamico e aggraziato allo stesso tempo.

The overlapping of materials and shapes emphasizes the beauty of the Necchi sofa characterized by a leather detail that covers both the base and the front of the armrests, making for a true hallmark of design that is both dynamic and graceful.



Monaco

SOFA DESIGN BY LUCA ERBA

Il divano Monaco è caratterizzato da un'intrigante rotondità della struttura, che abbraccia il cuscino monovolume di seduta, appoggiato su una base in pelle. Il dettaglio del bracciolo si sovrappone elegantemente alla seduta, diventandone il segno distintivo per un raffinato elemento decorativo.

The sofa Monaco features a charming roundness for the structure, which embraces the monovolume padded seat cushion, resting on a leather base. The detail of the armrest elegantly overlaps the seat, becoming the design hallmark for a fine decorative feature.



Monaco SOFA / Leni SMALL TABLE / Carrera PANELS



Monaco SOFA / Audrey ARMCHAIR / Leni SMALL TABLE / Carrera PANELS / Palladio MIRROR / Daisy VASES



Monaco SOFA & ARMCHAIR / Leni SMALL TABLE / Lanza SIDEBOARD / Casati CARPET



Le forme del divano Monaco si esprimono attraverso linee curve e organiche, valorizzando un design caratterizzato da un'attenta cura dei dettagli e da volumi accoglienti, dal fascino senza tempo.

The Monaco sofa's design is expressed through soft, curved, and organic lines, highlighting meticulous attention to detail and welcoming volumes with a timeless appeal.



Monaco SOFA & ARMCHAIR / Leni SMALL TABLE / Cusani CARPET

Audrey

ARMCHAIR DESIGN BY GIORGIO BONAGURO

La poltrona Audrey racconta di volumi sovrapposti dalle proporzioni avvolgenti per un susseguirsi di curve morbide in contrasto alla base in legno dove il design si fa poesia. Una seduta che è insieme rifugio e elemento scultoreo per la sua presenza scenica nello spazio del living.

The Audrey armchair tells of overlapping volumes with enveloping proportions for a succession of soft curves in contrast to the wooden base where design becomes poetry. A seating that is both a refuge and a sculptural element for its scenic presence in the living space.



Audrey ARMCHAIR / Adami SMALL TABLE



Audrey nasce dall'incontro tra equilibrio formale e sensibilità materica. Le sue geometrie morbide si sviluppano in un dialogo armonico tra pieni e vuoti. Una poltrona pensata per abitare lo spazio con naturalezza, capace di unire comfort e identità scultorea in un'unica, elegante presenza.

Audrey is born from the meeting of formal balance and material sensitivity. Its soft geometries unfold in a harmonious dialogue between solids and voids. An armchair designed to inhabit the space with ease, combining deep comfort and sculptural identity in a single, elegant presence.



Necchi

ARMCHAIR DESIGN BY ANDREA BONINI

Dalla collezione di divani Necchi nasce, come naturale evoluzione, l'omonima poltrona, che ne esalta l'eleganza in una versione più raccolta. Le sue dimensioni contenute mettono in risalto i dettagli raffinati della base in pelle, che avvolge con continuità anche il frontale dei braccioli, abbracciando le morbide sedute. Un complemento di grande classe, dove comfort e ricercatezza si fondono in un equilibrio perfetto.

From the Necchi sofa collection comes, as a natural evolution, the eponymous armchair, which enhances its elegance in a more compact version. Its small dimensions highlight the refined details of the leather base, which also wraps the front of the armrests with continuity, embracing the soft seats. A complement of great class, where comfort and refinement come together in a perfect balance.



Necchi ARMCHAIR / Adami SMALL TABLE / Cusani CARPET

La poltrona Necchi si caratterizza da dimensioni raccolte e dal design importante, in un equilibrio fra l'utilizzo di diversi materiali e morbidezze che rendono la seduta un nido accogliente.

The Necchi armchair is characterized by its compact size and striking design, a balance between the use of different materials and softness that make the seat a cozy nest.



Monaco

ARMCHAIR DESIGN BY LUCA ERBA

Il segno distintivo del bracciolo, che si sovrappone morbidamente al cuscino imbottito della seduta monovolume, diventa la caratteristica principale della poltrona Monaco, parte dell'omonima collezione. Un'isola di estremo benessere dal design raffinato per un living dal gusto glamour e contemporaneo.

The hallmark of the armrest softly overlapping on the padded monovolume seating cushion becomes the main feature of the armchair Monaco, part of the namesake collection. An island of extreme coziness and refined design for a living with a glamour contemporary taste.



Monaco ARMCHAIR / Cusani CARPET



Silhouette avvolgente dalla forma sinuosa, la poltrona Monaco esalta il design e la cura dei dettagli della collezione Vittoria Frigerio per un arredo di personalità di grande eleganza.

An enveloping silhouette with a sinuous shape, the Monaco armchair enhances the design and attention to detail of the Vittoria Frigerio collection for a very elegant piece of furniture with personality.

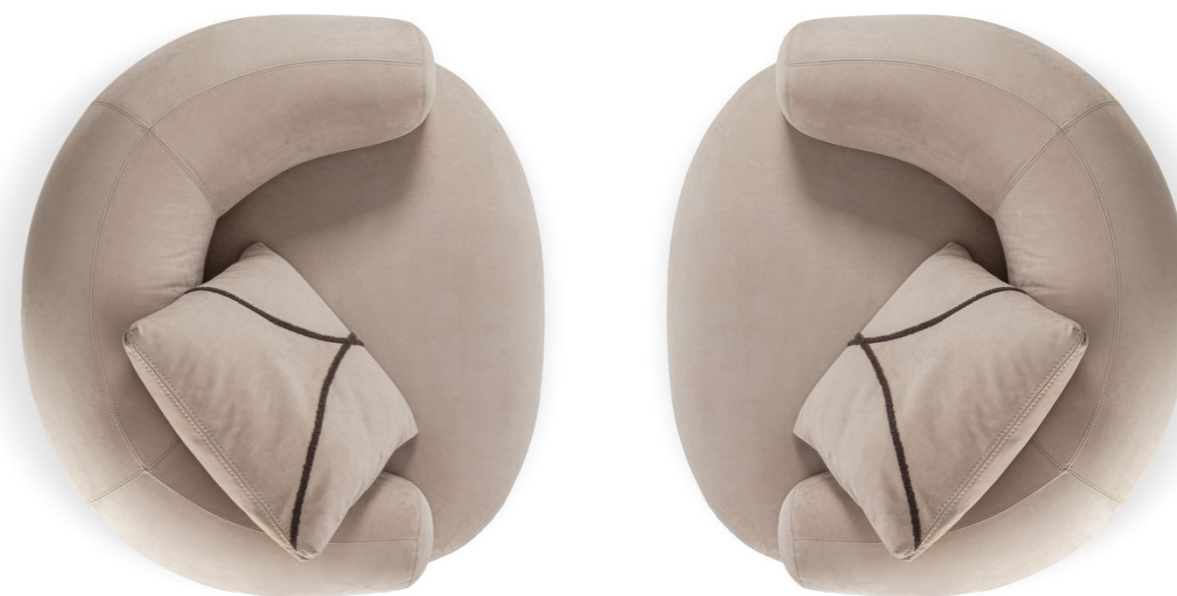

Mora

LOVESEAT DESIGN BY STUDIO CATTANEO

Un piacevole elemento d'arredo in cui la rotondità della base crea un'isola di comfort e relax, dando vita a un loveseat caratterizzato dai dettagli della collezione Mora: un'elegante struttura in legno con schienale imbottito e cuscini di seduta con cucitura verticale.

A pleasing furnishing element where the roundness of the base creates an island of comfort and relaxation by creating a loveseat featuring the details of the Mora collection: sleek wooden frame with padded back and seat cushions with vertical sewing.



Mora LOVESEAT



Mora LOVESEAT / Vivaldi SOFA / Adami SMALL TABLE / Cusani CARPET



La cura dei dettagli esalta il loveseat Mora dove la struttura in legno massello abbraccia gli elementi imbottiti creando un oggetto che diventa protagonista della zona living.

Attention to detail enhances the Mora loveseat, where the solidwood frame embraces the padded elements, creating a piece that becomes the main character of the living area.

*Exquisite manufacturing
for excellent materials*



ROSSO LEVANTO
Marble

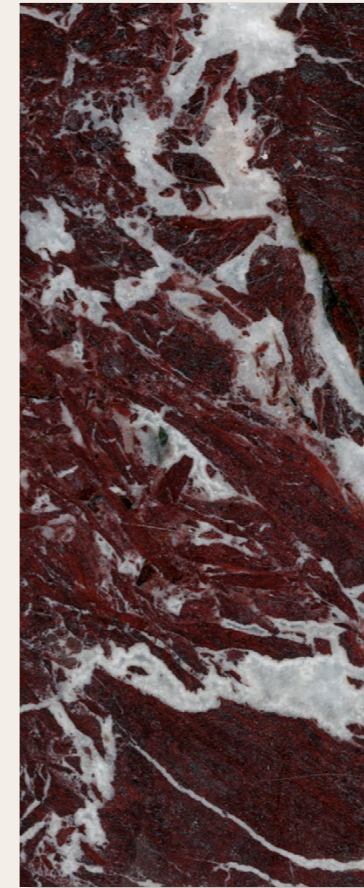

GROSGRAIN A56
Piping

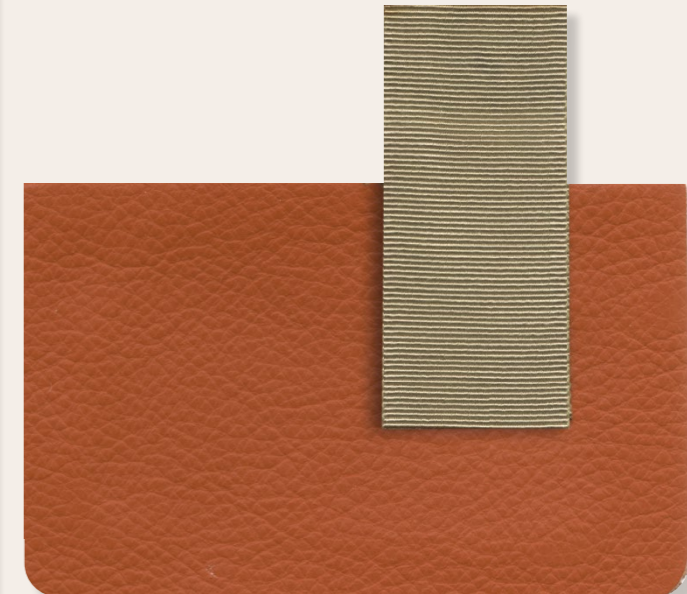

SIENA 5010
Leather

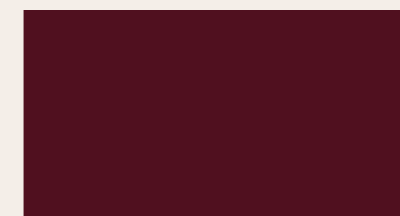

BURGUNDY
Lacquered



VF 1750/16
Fabric

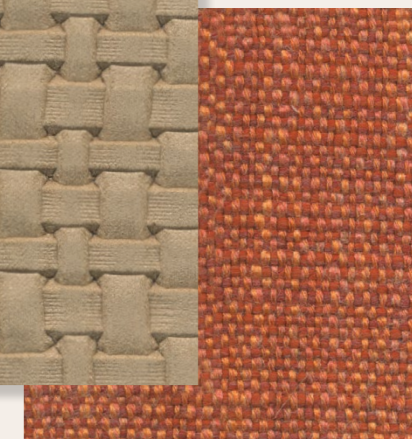

MADDALENA 13
Fabric

Gregory

TABLE DESIGN BY GIORGIO BONAGURO

Due gambe scultoree dalle forme speculari e specchiate che giocano con elementi pieni e vuoti e materiali contrastanti che danzano fra ordine e movimento e sorreggono il piano in marmo. Il tavolo Gregory non è solo funzione, ma espressione di una visione estetica di maestria artigianale.

Two sculptural legs with symmetrical yet mirrored forms that play with full and empty elements and contrasting materials that dance between order and movement, by supporting the marble top. The Gregory table is not just function, but an expression of an aesthetic vision of craftsmanship.



Gregory TABLE / Audrey SMALL ARMCHAIR / Lanza SIDEBOARD / Miani MIRROR



Gregory TABLE / Audrey SMALL ARMCHAIR / Lanza SIDEBOARD / Miani MIRROR



Il tavolo Gregory è espressione di maestria artigianale e ricerca tecnica. L'uso di materiali preziosi come il marmo, abbinato a elementi contemporanei come i colori laccati, creano abbinamenti inaspettati per un risultato unico.

The Gregory table is an expression of master craftsmanship and technical research. The use of precious materials such as marble, combined with contemporary elements such as lacquered colors, creates unexpected combinations for a unique result.



Monroy

TABLE DESIGN BY GIORGIO BONAGURO

Il tavolo da pranzo Monroy mette in risalto il design delle gambe a forma di due vele contrapposte dando vita a una soluzione da pranzo dalle linee nette e pure, enfatizzando l'uso dei materiali. Il piano è in marmo e per le gambe si nota un inaspettato abbinamento: la gamba è in marmo e la parte esterna è rivestita da una lastra di metallo, per un forte contrasto materico.

The dining table Monroy highlights the design of the legs shaped like two opposite sails giving life to a dining solution featuring sharp and pure lines by emphasizing the use of the materials. The top is made of marble and the legs feature an unexpected match: the leg is in marble and the external part is covered by a metal plate, for a strong contrast of matter.



Monroy TABLE / Grace SMALL ARMCHAIR / Casati CARPET



Monroy TABLE / Grace SMALL ARMCHAIR / Doge BOOKCASE / Casati CARPET



Il tavolo da pranzo Monroy si arricchisce dal dettaglio dell'inserito di metallo applicato sulla parte esterna delle gambe per una visione sia monocromatica che inaspettatamente in contrasto, a seconda del punto di vista.

The Monroy dining table is enriched by the detail of the metal insert applied to the outside of the legs for a vision both monochromatic and unexpectedly contrasting, depending on the point of view.

Audrey

CHAIR & SMALL ARMCHAIR DESIGN BY GIORGIO BONAGURO

La sedia e poltroncina Audrey raccontano di volumi sovrapposti e avvolgenti per un susseguirsi di curve morbide in contrasto alla base in legno dove il design si fa poesia. Una seduta che è insieme rifugio e elemento scultoreo per la sua presenza scenica nello spazio della zona dining.

The Audrey chair and small armchair tell of overlapping volumes with enveloping proportions for a succession of soft curves in contrast to the wooden base where design becomes poetry. A seating that is both a refuge and a sculptural element for its scenic presence in the dining area.



Audrey CHAIR



Audrey SMALL ARMCHAIR



Audrey SMALL ARMCHAIR & CHAIR / **Gregory** TABLE / **Lanza** SIDEBOARD / **Palladio** MIRROR



Audrey SMALL ARMCHAIR & CHAIR / Gregory TABLE / Monroy CONSOLE



La sedia e poltroncina Audrey rispecchiano il segno distintivo della collezione con proporzioni differenti per realizzare due versioni che possano soddisfare ogni esigenza della zona dining con un design avvolgente.

The Audrey chair and small armchair reflect the distinctive style of the collection with different proportions to create two versions that can satisfy every need in the dining area with an enveloping design.



Grace

SMALL ARMCHAIR DESIGN BY ANDREA BONINI

Poltroncina con linee pulite e rigorose definisce un design costruttivo di grande tecnica grazie ad una struttura in legno dalla silhouette aerea che trasforma le gambe in braccioli per una seduta esteticamente pura e accogliente. L'uso di materiali diversi e i dettagli sartoriali per la seduta e lo schienale evidenziano lo spirito manifatturiero della collezione.

A small armchair whose clean, rigorous lines defines a highly technical construction silhouette with an aerial wooden frame that transforms the legs into armrests for an aesthetically pure and welcoming seat. The use of different materials and the tailoring details of the seat and back highlight the handcrafted spirit of the collection.



Grace SMALL ARMCHAIR / Monroy TABLE / Casati CARPET



Maestria artigianale e design senza tempo si combinano armoniosamente grazie all'uso sapiente di materiali esclusivi come il legno massello per la struttura e il mix fra tessuto e pelle per la seduta e schienale.

Craftsmanship and timeless design are harmoniously combined thanks to the skilful use of exclusive materials such as solid wood for the structure and the mix of fabric and leather for the seat and backrest.



Monroy TABLE / Grace SMALL ARMCHAIR / Casati CARPET

Mora

CHAIR DESIGN BY STUDIO CATTANEO

All'omonima collezione si aggiunge una sedia con braccioli caratterizzata dalla struttura in legno massello che dai braccioli si estende nella base semicircolare per un'elegante sedia per la zona dining. La sedia con braccioli Mora arreda con uno stile senza tempo la sala da pranzo, grazie alla struttura in legno e alla seduta rivestita in materiali ricercati.

A chair with armrests is added to the collection of the same name, featuring a solid wood frame extending from the armrests into the semicircular base for an elegant dining chair. The Mora chair with armrests furnishes the dining area with timeless style, thanks to its wooden frame and seat upholstered in refined materials.



Mora CHAIR / Corsini TABLE / Casati CARPET

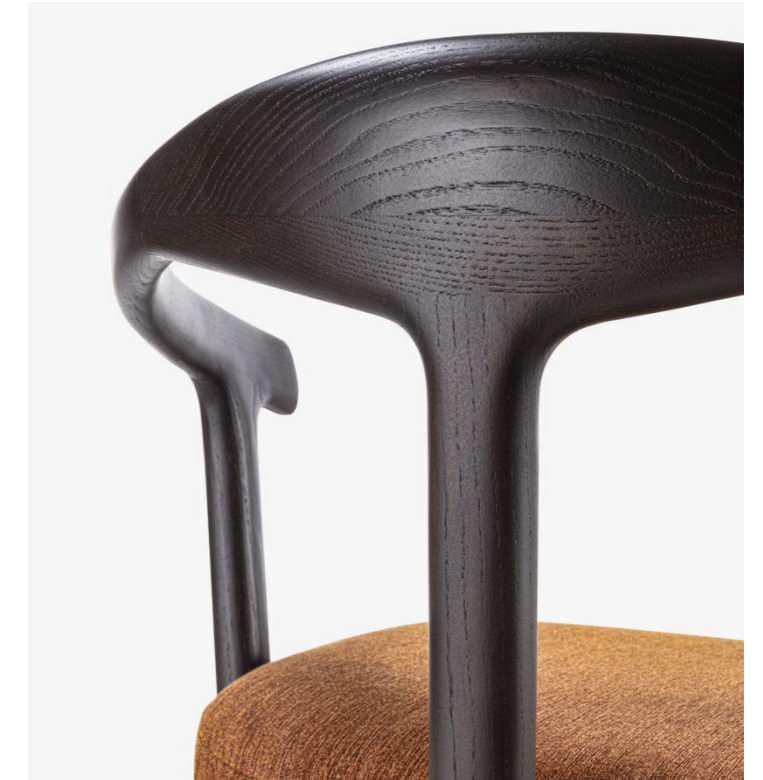

La sedia Mora con braccioli è un progetto che coniuga forma e funzione e grazie alla struttura in legno massello viene esaltata l'artigianalità della produzione Vittoria Frigerio. Perfetta per ambienti living o dining, aggiunge un elemento di classe a qualsiasi spazio.

The Mora chair with armrests is a design that combines form and function, and thanks to the solid wood frame the craftsmanship of Vittoria Frigerio production is enhanced. Perfect for living or dining environments, it adds an element of class to any space.

Necchi

SMALL TABLE & SERVER DESIGN BY ANDREA BONINI

Il tavolino Necchi è caratterizzato da un'inaspettata forma ovale che racchiude un piano in legno. Quest'ultimo è arricchito da un piano decorativo rotondo in marmo. La base è rivestita in pelle e riprende il segno distintivo del divano Necchi, come nell'elemento server, disponibile solo con top in marmo.

The Necchi small table is characterized by an unexpected oval shape that encloses a wooden top. The latter is enriched by a decorative round marble top. The base is covered in leather and echoes the hallmark of the Necchi sofa, as in the server element, available only with a marble top.



Necchi SMALL TABLE & SERVER / Necchi ARMCHAIR



Necchi SMALL TABLE & SERVER / Necchi SOFA / Audrey ARMCHAIR



Dettagli raffinati e materiali preziosi: il tavolino Necchi si caratterizza dalla peculiare forma ovale con top in legno e inserto tondo in marmo con una struttura rivestita in pelle per un prodotto di un'eleganza senza tempo.

Refined details and precious materials: the Necchi small table is characterized by its distinctive oval shape with a wooden top and round marble insert with a leather-covered structure for a product of timeless elegance.



Leni

SMALL TABLE DESIGN BY LUCA ERBA

Il tavolino Leni sorprende per il design inaspettato del piano rotondo in marmo che non completa il suo perimetro circolare, creando un abbraccio tra le due estremità arrotondate del cerchio che rimane aperto. Il corpo centrale, in laccato lucido, fornisce ulteriori dettagli per un elemento che unisce funzionalità e design.

The small table Leni surprises you with an unexpected design of the marble round top which does not complete its circular perimeter, by creating an embrace between the two rounded ends of the circle which remains uncomplete. The central body, in lacquered glossy colour, provides further furnishing details to this extremely decorative small table for your living room.



Leni SMALL TABLE / Monaco SOFA / Cusani CARPET



I tavolini Leni propongono diversi tipi di marmo che conferiscono texture e materiali preziosi alla zona living.

Leni small tables offer different kind of marble providing textures and precious material into the living room.

Un raffinato design per una famiglia di tavolini tondi in diverse altezze e top in marmo. Le finiture disponibili permettono abbinamenti audaci per oggetti dal gusto unico e senza tempo.

A refined design for a family of round tables in different heights and with marble tops. The available finishes allow for bold combinations for objects with a unique and timeless style.





Leni SMALL TABLE / Monaco SOFA / Cusani CARPET

Monroy

SERVER DESIGN BY GIORGIO BONAGURO

Con un design minimalista e una silhouette puramente delineata, il server Monroy presenta un piano in marmo e una base a forma di triangolo aperto rovesciato, per un'aggiunta funzionale e raffinata alla zona living.

With a minimalistic design and a pure sharp silhouette, the server Monroy features a marble top and a base shaped like a reverse open triangle for a functional and refined addition to the living room.



Monroy SERVER / Spinola SOFA

Monroy

CONSOLE DESIGN BY GIORGIO BONAGURO

La console Monroy è caratterizzata da un design aereo grazie all'unica gamba che sostiene la console, a sua volta fissata alla parete. Monroy evidenzia un design estremo e puro, dove i materiali diventano i veri protagonisti della collezione con la gamba in marmo rivestita da un lato da una lastra di metallo.

The console Monroy features an aerial design thanks to the single leg supporting the console, fixed to the wall. Monroy features an extreme pure design where the materials become the true protagonists of the collection with the leg in marble covered on one side with a metal plate.



Monroy CONSOLE / Miani MIRROR

Brera

BENCH & DAYBED DESIGN BY ANDREA BONINI

Un nuovo oggetto per il living, che può essere utilizzato come panca sia nella zona giorno che nella zona notte. La versione daybed crea nuovi spazi di seduta e comfort. Brera è anche disponibile nella versione decorativa e funzionale con piano di appoggio integrato per offrire una maggiore superficie d'appoggio.

A new furnishing object that can be used as bench both in the living and in the night area. The daybed version creates new spaces for seating and comfort. Brera is also available in a decorative and functional version with an integrated top to provide more storage space.



Brera Plain BENCH / Lario Plain BED / Salis NIGHT TABLE



Eleganza senza tempo e materiali pregiati si incontrano nella panca Brera. Il rivestimento in tessuto avvolge la seduta, mentre gli inserti in pelle conferiscono un tocco di lusso e raffinatezza. Le gambe in legno massello sono impreziosite da dettagli in oro per un elemento d'arredo che unisce stile, comfort e unicità.

Timeless elegance and fine materials meet in the Brera bench. The seat is covered in precious fabric, while leather inserts add a touch of luxury and refinement. The solid wood legs are embellished with gold details for a piece of furniture that combines style, comfort and uniqueness.





Brera Plain BENCH / Necchi SOFA

*Glamour in motion
for luxury design*

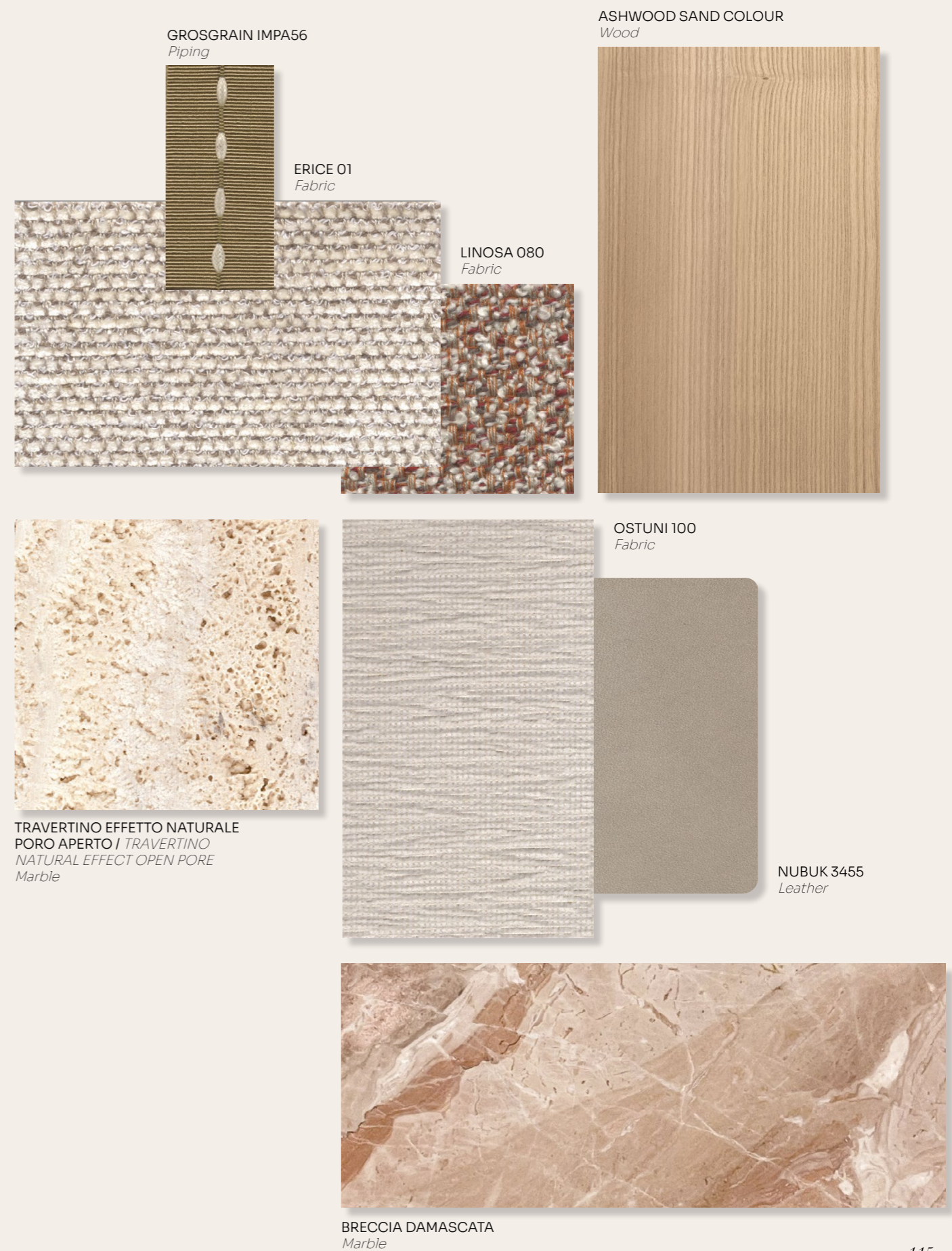

Lario

BED DESIGN BY ANDREA BONINI

Il letto Lario porta il design, la purezza delle linee e il rigore progettuale nel comfort di un letto lussuoso caratterizzato da un'alta testata con un'elegante struttura in legno che incornicia un pannello in tessuto o pelle che incornicia un pannello in tessuto o pelle impreziosito da un cuscino decorativo, liscio o trapuntato, per un delicato equilibrio tra la solida base e la leggera testata.

The Lario bed brings design, purity of lines, and architectural rigor to the comfort of a luxurious bed featuring a high headboard with an elegant wooden structure that frames a fabric or leather panel embellished with a decorative cushion either plain or quilted, for a delicate balance between the solid base and light headboard.



Lario Quilt BED



Lario Plain BED / Brera Plain BENCH / Salis NIGHT TABLE / Miani MIRROR / Pisani CARPET



Stile e raffinatezza caratterizzano il letto Lario per trasformare la zona notte in un'oasi di lusso. La maestosa testata è impreziosita da una trapunta in pelle che conferisce un senso di esclusività e comfort. Lusso, artigianalità e un'estetica impeccabile sono i segni distintivi di questo protagonista della zona notte.

Style and sophistication characterise the Lario bed to transform the night area into an oasis of luxury. The majestic headboard is embellished with a leather quilted insert that lends a sense of exclusivity and comfort. Luxury, craftsmanship and impeccable aesthetics are the hallmarks of this main character of the night area.



Carrera

SCREEN PANEL DESIGN BY R&D VITTORIA FRIGERIO

Carrera sono pannelli boiserie con texture dedicate, arricchiti da un profilo rivestito in pelle e retroilluminazione integrata. Disponibili in formati rettangolari, quadrati e tondi, arredano le pareti con un segno contemporaneo e raffinato, creando atmosfere luminose di grande impatto.

Carrera are boiserie panels with dedicated textures, enriched with a leather profile and integrated backlighting. Available in rectangular, square, and round shapes, they decorate walls with a contemporary and refined touch, creating striking, luminous environments.



Carrera SCREEN PANEL / Monroy CONSOLE



Carrera SCREEN PANEL / Monaco SOFA / Leni SMALL TABLE



I pannelli Carrera sono perfettamente integrati nella collezione VF. Il sapiente equilibrio tra pannelli, console e specchio crea un risultato unico per un design lussuoso e senza tempo.

Carrera panels are fully integrated with the VF collection. The wise balance between panels, console and mirror creates a unique results for a luxury design, yet timeless.



Carrera SCREEN PANEL / **Monroy** CONSOLE / **Miani** MIRROR

Chloé

BOOKCASE DESIGN BY R&D VITTORIA FRIGERIO

La libreria a muro Chloé, retroilluminata e rifinita in pelle, si apre grazie a due elementi tondi per un gioco di sorprendente modernità per la zona living, arredando con un movimento fluido ogni parete.

The wall bookcase Chloé, backlit and refined in leather, opens up thanks to round elements for a surprising contemporary play for the living area by furnishing with a fluid movement every wall.

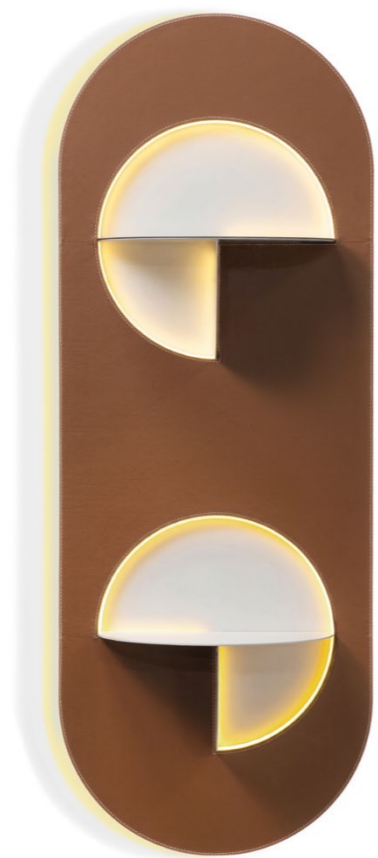

Chloé BOOKCASE / Noah SOFA



Chloé BOOKCASE / Gregory TABLE / Audrey SMALL ARMCHAIR

Il gioco di pieno e vuoto della libreria a muro Chloé diventa un elemento caratterizzante che permette di unire design, forma e funzione per un risultato di grande impatto scenico.

The interplay of full and empty spaces in the Chloé wall bookcase becomes a defining feature that combines design, form, and function for a striking visual effect.

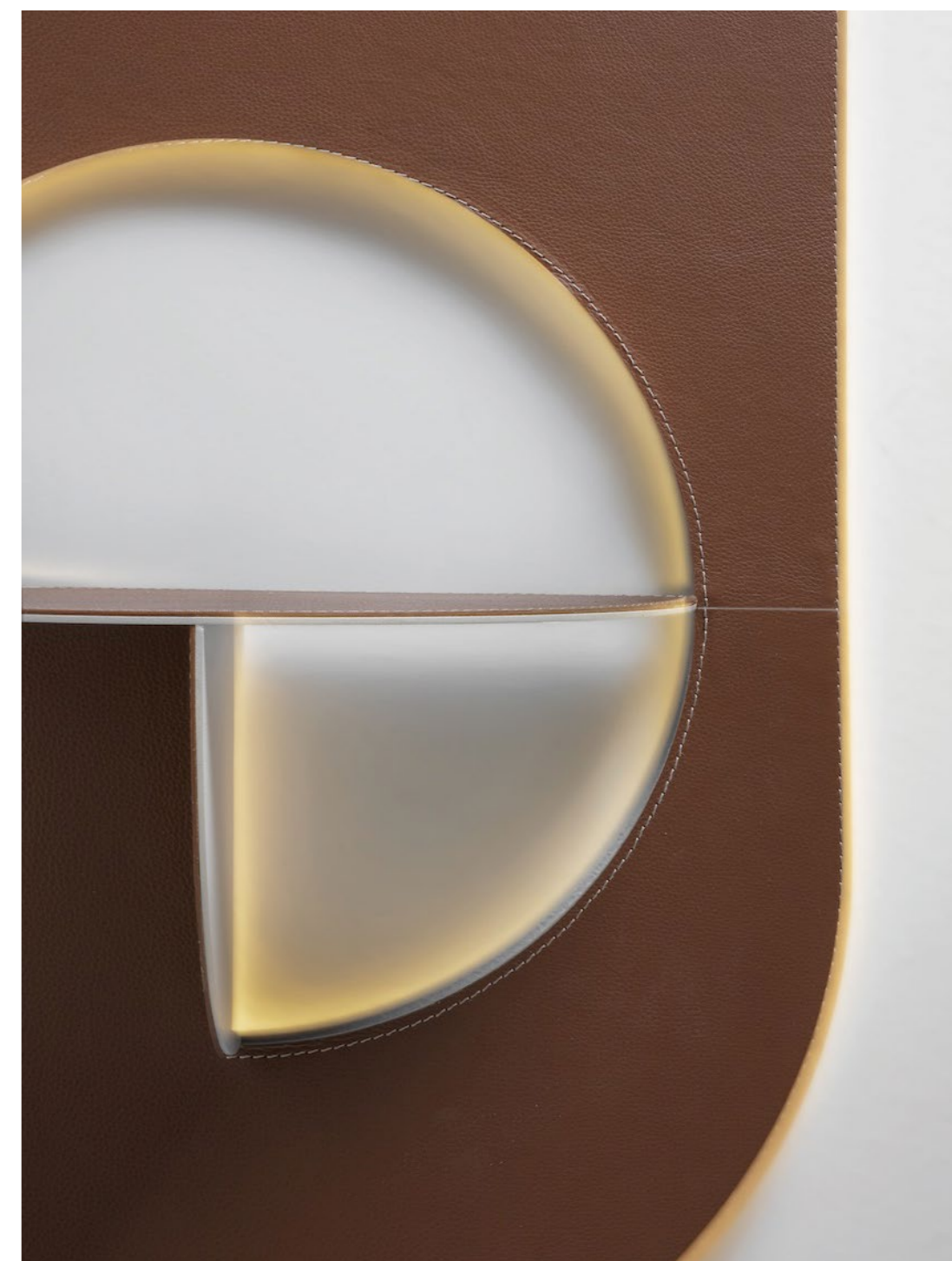

Vivienne

BOOKCASE DESIGN BY R&D VITTORIA FRIGERIO

Come l'architettura di una classica cattedrale rinascimentale, la libreria Vivienne si erge con eleganza scultorea. Una danza di elementi modulari, ornati da archi che sostengono ripiani in marmo. Una visione di fluidità, equilibrio e bellezza senza compromessi, che ospita libri e oggetti all'interno del suo design scultoreo.

Like the architecture of a classical renaissance cathedral, the Vivienne bookcase rises with sculptural elegance. A dance of modular elements, adorned with arches supporting marble shelves. A vision of fluidity, balance, and uncompromising beauty, hosting books and objets to rest within its sculptural design.



Vivienne BOOKCASE / Noah SOFA / Monroy SERVER



Vivienne BOOKCASE / Necchi ARMCHAIR / Adami SMALL TABLE / Brera Quilt BENCH / Cusani CARPET



Vivienne BOOKCASE

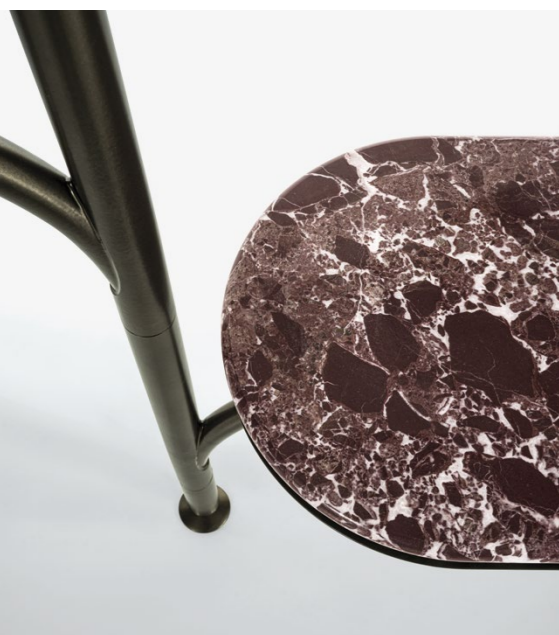

Dettagli in marmo, divisori in colori laccato lucido, montati in metallo: la libreria Vivienne racconta una cura dei dettagli estrema, sia nella parte tecnica che nel design, per una ricercatezza formale di purezza estetica e visiva.

Marble details, glossy lacquered color dividers, metal uprights: the Vivienne bookcase reflects extreme attention to detail, both in terms of technology and design, for a formal refinement of aesthetic and visual purity.



Roma

BOOKCASE DESIGN BY R&D VITTORIA FRIGERIO

Una libreria a giorno che può essere utilizzata come elemento singolo o sovrapponendole tra loro oppure affiancandole liberamente. Un intrigante elemento d'arredo per la zona living che dona un tocco di modernità per la libertà compositiva e per un tocco di tradizione grazie alla struttura in legno.

An open bookcase that can be used as a single element or by overlapping them or by freely placing them side by side. An intriguing piece of furniture for the living area that gives a touch of modernity thanks to the modularity freedom and a touch of tradition thanks to the wooden structure.



Roma BOOKCASE / Spinola SOFA / Adami SMALL TABLE / Cusani CARPET



La libreria Roma si caratterizza da elementi sovrapponibili con dettagli esclusivi, come gli inserti in cuoio e i ripiani in vetro bronzato, per un risultato estetico di grande ricercatezza formale senza rinunciare alla funzionalità.

Roma bookcase features stackable elements with exclusive details such as hide-leather inserts and bronzed glass shelves, for an aesthetic result of great formal refinement without sacrificing functionality.



Roma BOOKCASE / Spinola SOFA / Adami SMALL TABLE / Cusani CARPET

Daisy

VASES DESIGN BY R&D VITTORIA FRIGERIO

La collezione di vasi decorativi Daisy, rivestiti in morbido tessuto effetto nabuk, arricchisce la proposta VF con elementi di estrema grazia e impatto visivo. Pensata per arredare con ricercata sobrietà, la linea Daisy conferisce un tocco di eleganza discreta a ogni area del living.

The Daisy decorative vase collection, upholstered in a soft nubuck-effect fabric, is a new addition to the VF range. These pieces bring extreme grace and visual appeal to any space, designed to decorate every living area with refined sophistication and effortless elegance.



Daisy VASES

SOFA DESIGN BY R&D VITTORIA FRIGERIO

Collezione di divani ed elementi componibili caratterizzati da sezioni imbottite verticali su seduta e schienale, in tessuto o pelle, con rivestimento non sfoderabile.

Collection of sofas and modular elements featuring vertical padded section on seat and backrest, in fabric or leather, with fixed cover.



COMPOSIZIONI / COMPOSITIONS

pag. 12-13

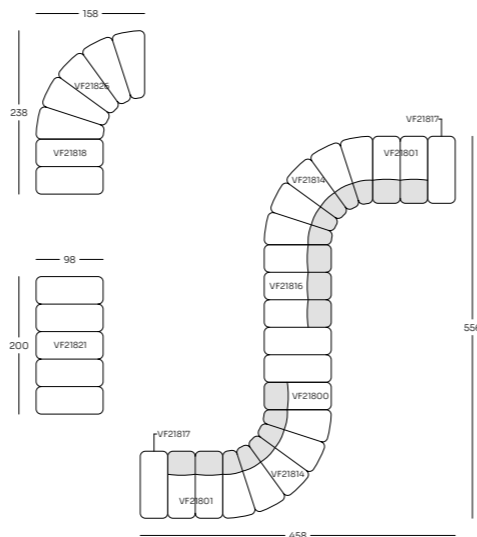
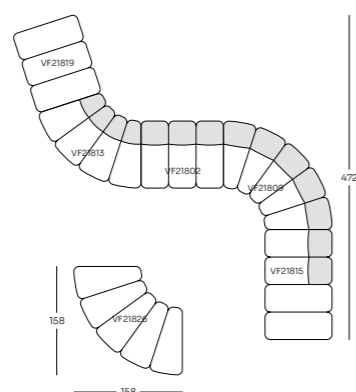

pag. 16-17

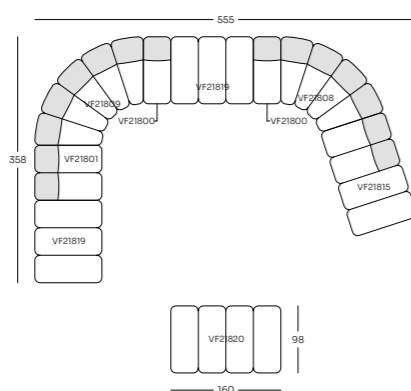

pag. 18-19

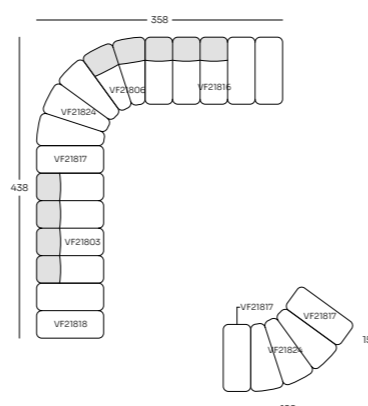

SOFA DESIGN BY ANDREA BONINI

Collezione di divani ed elementi componibili in tessuto o pelle con rivestimento non sfoderabile. Basamento rivestito in pelle così come la parte anteriore dei braccioli, sempre con rivestimento fisso.

Collection of sofas and modular elements in fabric or leather with fixed cover. Base covered in leather as well as the front part of the armrests, always with fixed cover.



COMPOSIZIONI / COMPOSITIONS

pag. 23 - 25

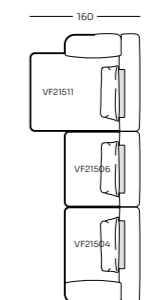
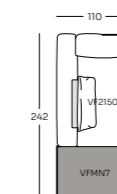

pag. 26 - 27

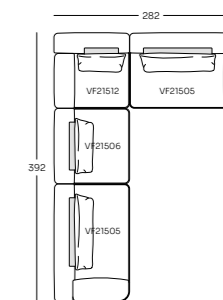

pag. 30 - 31

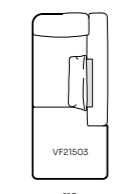
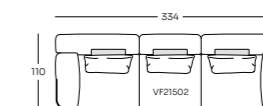

MONACO / PAG 35

SOFA DESIGN BY LUCA ERBA



Collezione di divani ed elementi componibili in tessuto o pelle con rivestimento non sfoderabile. Basamento rivestito in pelle. Completa la collezione una poltrona.

Collection of sofas and modular elements in fabric or leather with fixed cover. Base in leather. An armchair completes the collection.

COMPOSIZIONI / COMPOSITIONS

pag. 38 - 39

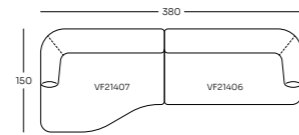

pag. 36 - 37

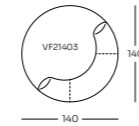
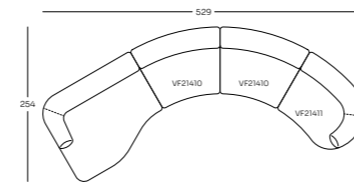

pag. 42 - 43

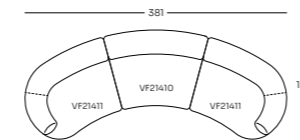

MONACO / PAG 53

ARMCHAIR DESIGN BY LUCA ERBA



Poltrona in tessuto o pelle con rivestimento non sfoderabile. Basamento rivestito in pelle.

Armchair in fabric or leather with fixed cover. Base in leather.

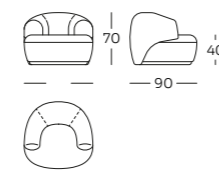

NECCHI / PAG 49

ARMCHAIR DESIGN BY ANDREA BONINI



Poltrona tessuto o pelle con rivestimento non sfoderabile. Basamento rivestito in pelle così come la parte anteriore dei braccioli, sempre con rivestimento fisso.

Armchair in fabric or leather with fixed cover. Base covered in leather as well as the front part of the armrests, always with fixed cover.

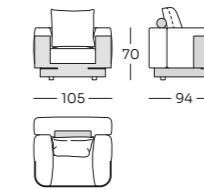

AUDREY / PAG 45

ARMCHAIR DESIGN BY GIORGIO BONAGURO



Poltrona con basamento in legno massello e seduta e schienale rivestiti in tessuto o pelle o nella versione con schienale in pelle e interno in tessuto, rivestimento non sfoderabile. Schienale impreziosito da fasce imbottite di varie dimensioni.

Armchair with base in solid wood and padded seat and back covered in fabric or leather or available in the version externally in leather and internally in fabric, non-removable cover. Backrest enriched by padded strip in different sizes.

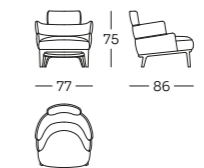

MORA / PAG 57

LOVESEAT DESIGN BY STUDIO CATTANEO



Loveseat con struttura a vista in legno massello e parti imbottite rivestite in tessuto o pelle con rivestimento non sfoderabile. Cuscino seduta e schienale impreziositi da ricami dedicati.

Loveseat with visible solid wood structure and padded parts covered in fabric or leather with a non-removable cover. Seat and back cushion enriched with dedicated embroidery.

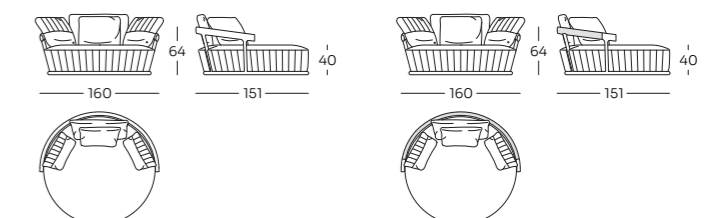

GREGORY / PAG 65

TABLE DESIGN BY GIORGIO BONAGURO



Collezione di tavoli da pranzo in varie dimensioni con top in marmo. Gambe in marmo nella stessa finitura del top con parte interna laccata a scelta.

Collection of dining tables in different sizes with marble top. Legs in marble in the same finish of the top with the internal part lacquered at choice.

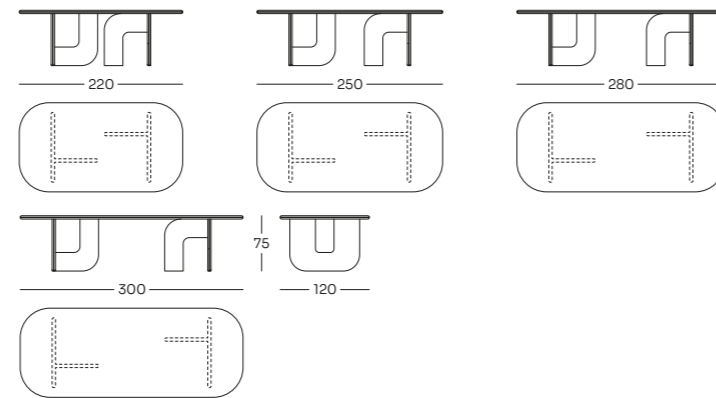

MONROY / PAG 71

TABLE DESIGN BY GIORGIO BONAGURO



Collezione di tavoli da pranzo di varie dimensioni con top in marmo. Gambe in marmo nella stessa finitura del piano, impreziosite da pannelli decorativi in metallo nella parte esterna.

Collection of dining table in different sizes with marble top. Legs in marble in the same finish of the top enriched by decorative metal panel on the external part of them.

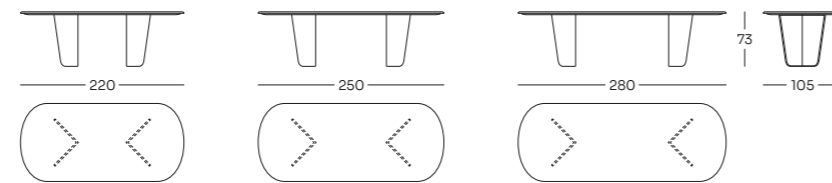

AUDREY / PAG 77

CHAIR & SMALL ARMCHAIR DESIGN BY GIORGIO BONAGURO



Audrey CHAIR

Audrey SMALL ARMCHAIR

Sedia e poltroncina con basamento in legno massello e seduta e schienale rivestiti in tessuto o pelle o nella versione con schienale nella parte esterna in pelle e interno in tessuto, rivestimento non sfoderabile. Schienale impreziosito da fasce imbottite di varie dimensioni.

Armchair with base in solid wood and padded seat and back covered in fabric or leather or available in the version externally in leather and internally in fabric, non-removable cover. Backrest enriched by padded strip in different sizes.

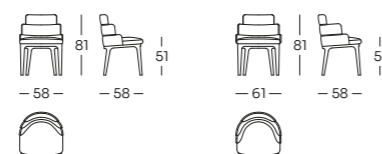

GRACE / PAG 83

SMALL ARMCHAIR DESIGN BY ANDREA BONINI



Poltroncina con gambe e braccioli in legno. Scocca di seduta e braccioli in legno imbottita internamente, con parte esterna rifinita con ricamo in rilievo, in tessuto o pelle. Cuscino schienale imbottito in tessuto o pelle. Disponibile anche nella versione rivestita internamente in tessuto e esternamente in pelle.

Small armchair with legs and armrests in solid wood. Seat and armrests body in wood padded internally, with the external part realized with embroidery in relief, in fabric or leather. Padded back cushion in fabric or leather. Available also in the version with internal part covered in fabric and external part in leather.

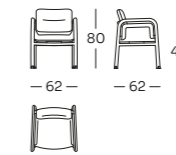

MORA / PAG 89

CHAIR DESIGN BY STUDIO CATTANEO



Sedia con braccioli con struttura a vista in legno massello e cuscino di seduta imbottito rivestito in tessuto o pelle, rivestimento non sfoderabile.

Chair with armrests with visible solid wood structure and padded seat cushion covered in fabric or leather, fixed cover.

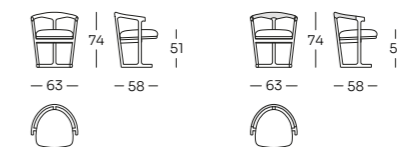

NECCHI / PAG 93

SMALL TABLE & SERVER DESIGN BY ANDREA BONINI



Collezione di tavolini in varie dimensioni con basamento rivestito in pelle e top in legno. Tavolino ovale disponibile con top in legno e inserto decorativo tondo in marmo. Server con basamento rivestito in pelle e top solo in marmo.

Collection of small table in different sizes with base covered in leather and top in wood. Oval small table available with wooden top and decorative round marble insert. Server with base covered in leather and top only in marble.

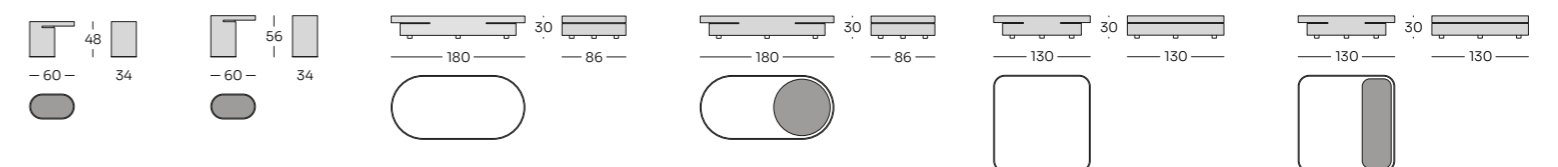

LENI / PAG 99

SMALL TABLE DESIGN BY LUCA ERBA



Collezione di tavolini in varie dimensioni con struttura e parte centrale del top in finitura laccato lucido. Top in marmo definito da un anello aperto con angoli stondati.

Collection of small tables in different sizes with structure and central top in glossy lacquered finish. Marble top defined by an open ring with rounded ends.

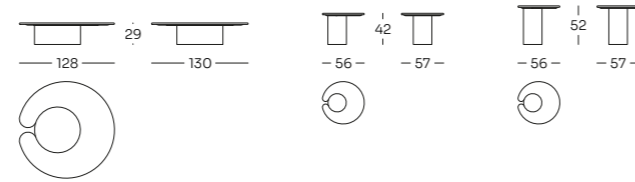

MONROY / PAG 105

SERVER DESIGN BY GIORGIO BONAGURO



Server con gamba centrale con top in marmo. Gamba in marmo nella stessa finitura del top con pannello decorativo in metallo nella parte esterna.

Server with central leg with marble top. Leg in the same marble of the top with a decorative metal panel on the external part of it.

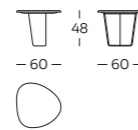

MONROY / PAG 107

CONSOLE DESIGN BY GIORGIO BONAGURO



Console con gamba singola e fissaggio a muro. Top in marmo. Gamba in marmo nella stessa finitura del piano, impreziosita da un pannello decorativo in metallo nella parte esterna.

Console with single leg and wall mounting. Marble top. Leg in marble in the same finish of the top enriched by a decorative metal panel on the external part of it.

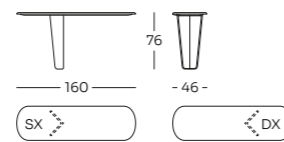

BRERA / PAG 109

BENCH & DAYBED DESIGN BY ANDREA BONINI



Collezione di panche in diverse dimensioni con piedini in legno massello e dettagli in metallo. Basamento rivestito in pelle con fascia decorativa in pelle incrociata alle estremità del cuscino seduta. Cuscino seduta rivestito in pelle o tessuto non sfoderabile, disponibile nella versione liscia o con trapunta dedicata. Disponibile la versione panca con top integrato e nella versione Plain e Quilt.

Collection of benches in different sizes with solid wooden feet and metal details. Leather base with decorative crisscrossed leather band at the end sides of the seat cushion. Seat cushion with non-removable cover in leather or fabric, available in either plain or in a dedicated quilted version. Bench version with integrated top and in the Plain and Quilt version.



BRERA QUILT BRERA PLAIN

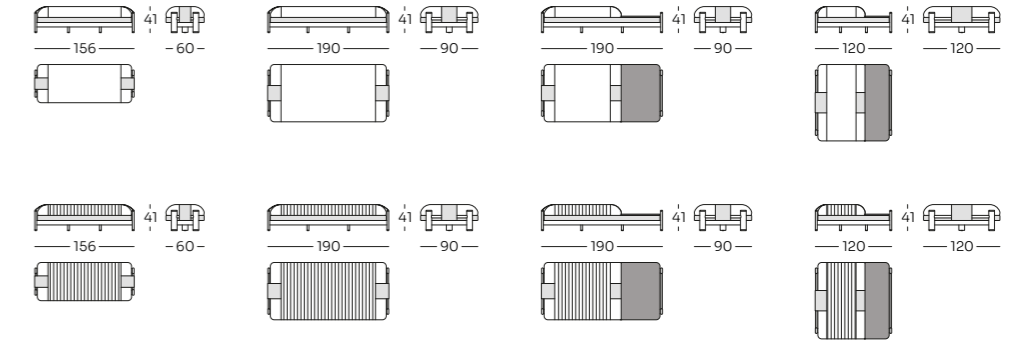

LARIO / PAG 117

BED DESIGN BY ANDREA BONINI



Collezione di letti completi di rete a doghe in legno (materasso escluso). Giroletto rivestito in tessuto o pelle non sfoderabile con basamento in pelle. Testata con cornice esterna in legno massello e dettagli in metallo e con inserto imbottito rivestito in tessuto o pelle. Disponibile nella versione Plain e Quilt.

Collection of beds with wooden slatted base (mattress excluded). Bedframe covered in non-removable fabric or leather with a leather base. Headboard with solid wood outer frame with metal details and upholstered insert covered in fabric or leather. Available in the Plain and Quilt version.

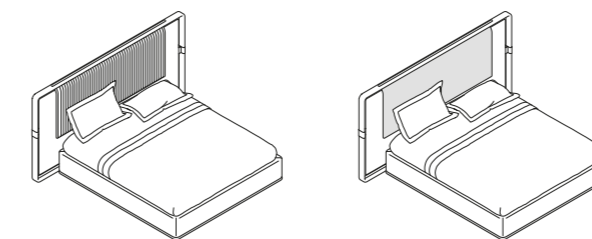

LARIO QUILT LARIO PLAIN

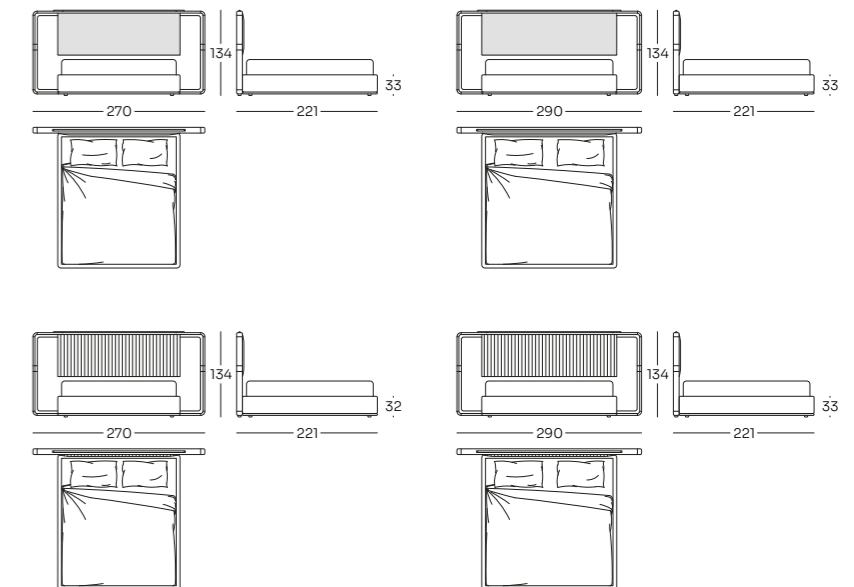

CARRERA / PAG 123

SCREEN PANEL DESIGN BY R&D VITTORIA FRIGERIO

Boiserie a muro con carta da parati dedicata e cornice in pelle Pisa o Siena, retroilluminato

Screen Panel wall fixing with dedicated wallpaper and frame in leather Pisa or Siena, backlit.

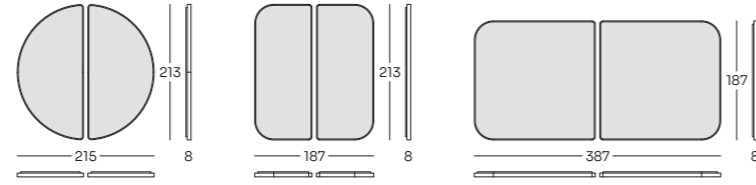

CHLOÉ / PAG 129

BOOKCASE DESIGN BY R&D VITTORIA FRIGERIO

Libreria a muro retroilluminata in metallo rivestita in pelle Pisa o Siena. Si caratterizza da due vani passanti circolari all'interno dei quali sono presenti mensole semicircolari, supportate da elementi verticali, che forniscono superfici d'appoggio per libri o oggetti decorativi in metallo laccato e pelle.

Wall-fixing backlit bookcase in metal covered in leather Pisa or Siena. It features two circular through compartments with semicircular shelves supported by vertical elements, providing support surfaces for books or decorative objects in lacquered metal and leather.

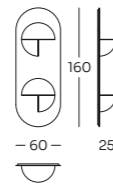
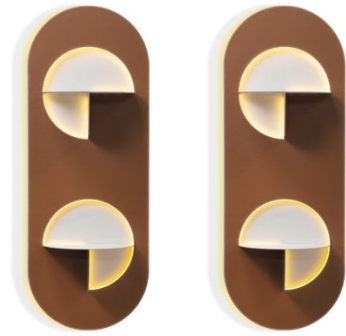

VIVIENNE / PAG 135

BOOKCASE DESIGN BY R&D VITTORIA FRIGERIO

Libreria con elementi strutturali/montante in metallo verniciato. Ripiani in marmo con doppia bisellatura e distanziale in legno che poggiano su elementi ad arco fissati alla struttura principale. Ripiani in marmo interposti su supporti verticali in metallo laccato.

Bookcase with structural elements/upright in lacquered metal. Shelves in marble with double bevel and wooden spacer resting on arched elements attached to the main structure. Interposed marble shelves on vertical supports in lacquered metal.

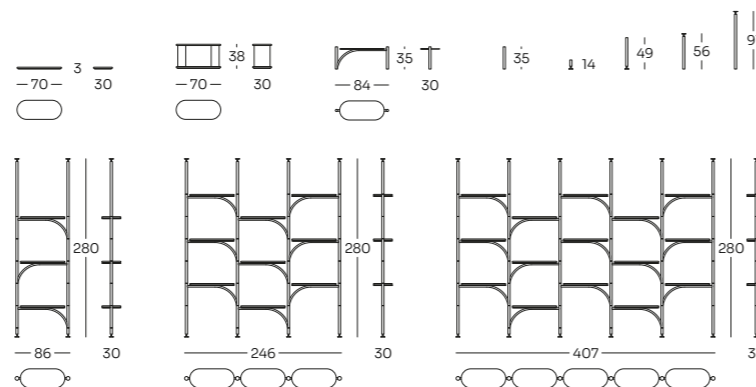

ROMA / PAG 143

BOOKCASE DESIGN BY R&D VITTORIA FRIGERIO

Libreria con struttura cilindrica in legno con inserti in cuoio, disponibile in due altezze e due versioni, con o senza ripiano centrale in vetro. Libreria impilabile e con luce led lungo l'altezza. Versione non girevole.

Bookcase with cylindrical wooden structure with hide-leather inserts, available in two heights and two versions, with or without central glass shelf. Stackable bookcase with led light along the height. Non-swivelling version.

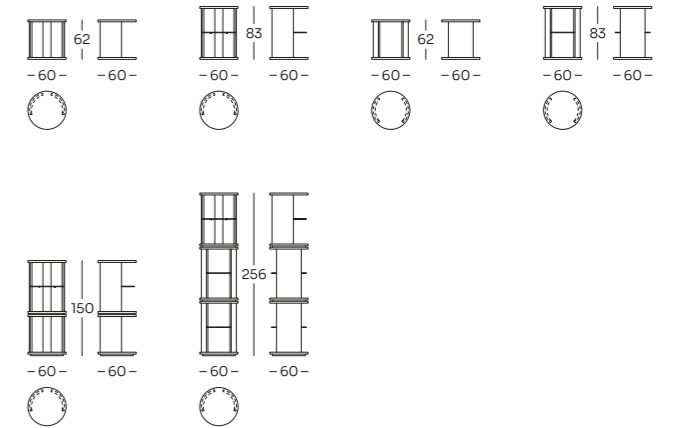

DAISY / PAG 149

VASES DESIGN BY R&D VITTORIA FRIGERIO

Vasi decorativi rivestiti in tessuto effetto nubuck Nevea con logo ricamato e impunture in contrasto.

Decorative vases covered in nubuck-effect fabric Nevea with embroidered logo and stitches in contrast.

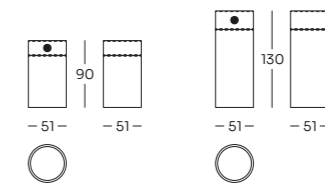

Art Direction:

Euro Sironi

Graphic Project:

Michela Boglietti

Project Coordination:

R&D Frigerio

Photo:

Studio Eleven

Images:

Francesca Fani Studio

Styling:

Euro Sironi

Colour Separation:

CD Cromo

Printing:

Grafiche Antiga



FRIGERIO POLTRONE E DIVANI SRL
Via Sant'Agata, 63
22066 Mariano Comense CO - Italy
T. +39 031 5481225
info@vittoriafrigerio.it
www.vittoriafrigerio.it

